

Operating Guide

VLT® Soft Starter MCD 600



Contents

1	Introduction	8
1.1	Product Description	8
1.2	Document Version	8
1.3	Additional Resources	8
1.4	Approvals and Certifications	8
2	Safety	9
2.1	Safety Symbols	9
2.2	Qualified Personnel	9
2.3	Safety Precautions	9
3	System Design	12
3.1	Feature List	12
3.2	Type Code	13
3.3	Selection of Soft Starter Size	13
3.4	Current Ratings (IEC Ratings)	14
3.5	Current Ratings (NEMA Ratings)	17
3.6	Dimensions and Weight	19
3.7	Physical Installation/Cooling Clearances	20
3.8	Accessories	21
3.8.1	Expansion Cards	21
3.8.1.1	Smart Card	21
3.8.1.2	Communication Expansion Cards	21
3.8.1.3	Ground Fault Protection	21
3.8.2	Remote LCP 601	21
3.8.3	Finger Guard Kit	22
3.8.4	Soft Starter Management Software	22
3.9	Main Contactor	22
3.10	Circuit Breaker	22
3.11	External Bypass Contactor	22
3.12	Power Factor Correction	22
3.13	Short-circuit Protection Devices	23
3.13.1	Type 1 Coordination	23
3.13.2	Type 2 Coordination	23
3.14	IEC Coordination with Short-circuit Protection Devices	24
3.15	UL Coordination with Short-circuit Protection Devices	25
3.15.1	Standard Fault Short Circuit	25

3.15.1.1	Models MCD6-0020B~MCD6-0579B	25
3.15.1.2	Models MCD6-0654B~MCD6-1250B & MCD6-0590C~MCD6-1134C	26
3.15.2	High Fault Short-circuit Current Ratings	26
4	Specifications	29
4.1	Supply	29
4.2	Short-circuit Capability	29
4.3	Electromagnetic Capability (Compliant with EU Directive 2014/35/EU)	29
4.4	Inputs	29
4.5	Outputs	29
4.6	Environmental	29
4.7	Heat Dissipation	30
4.8	Motor Overload Protection	30
4.9	Certification	30
4.10	Operational Life (Internal Bypass Contacts)	30
5	Installation	31
5.1	Safety Instructions	31
5.2	Command Source	31
5.3	Setting up the Soft Starter	31
5.4	Inputs	32
5.4.1	Input Terminals	32
5.4.2	Motor Thermistor	32
5.4.3	Start/Stop	33
5.4.4	Reset/Starter Disable	33
5.4.5	Programmable Inputs	33
5.4.6	USB Port	33
5.5	Outputs	34
5.5.1	Output Terminals	34
5.5.2	Analog Output	34
5.5.3	Main Contactor Output	34
5.5.4	Bypass Contactor Output	35
5.5.5	Programmable Outputs	36
5.6	Control Voltage	36
5.6.1	Control Voltage Terminals	36
5.7	Power Terminations	36
5.7.1	Wiring Connectors	38
5.7.1.1	Models MCD6-0144B~MCD6-0579B	38
5.7.1.2	Models MCD6-0654B~MCD6-1250B & MCD6-0590C~MCD6-1134C	39

5.8	External Bypass Contactor	39
5.9	Motor Connection	39
5.9.1	In-line Installation, Internally Bypassed	40
5.9.2	In-line Installation, Externally Bypassed	40
5.9.3	Inside Delta Installation, Internally Bypassed	41
5.9.4	Inside Delta Installation, Externally Bypassed	41
5.9.5	Ground Terminations	42
5.10	Typical Installations	42
5.10.1	Internally Bypassed Installation	42
5.10.2	Externally Bypassed Installation	44
5.11	Quick Set-up	46
6	Set-up Tools	48
6.1	Introduction	48
6.2	Setting Date and Time	48
6.3	Command Source	31
6.4	Commissioning	48
6.5	Run Simulation	48
6.6	Load/Save Settings	49
6.7	USB Save & Load	50
6.7.1	Save and Load Procedure	50
6.7.2	File Locations and Formats	50
6.8	Auto-start/Stop	51
6.9	Network Address	51
6.9.1	Setting a Network Address	51
6.10	Digital I/O State	52
6.11	Analog I/O State	53
6.12	Serial Number & Rating	53
6.13	Software Versions	53
6.14	Thermistor Reset	53
6.15	Reset Thermal Model	54
7	Logs	55
7.1	Introduction	55
7.2	Event Log	55
7.3	Counters	55
7.3.1	Viewing the Counters	55
7.4	QR Code	55

8	LCP and Feedback	56
8.1	Local LCP and Feedback	56
8.2	Remote LCP	56
8.3	Adjusting the Display Contrast	57
8.4	Soft Starter Status LEDs	58
8.5	Displays	58
8.5.1	Soft Starter Information	58
8.5.2	Configurable Feedback Screens	58
8.5.3	Operating Feedback Screens	58
8.5.4	Performance Graph	59
9	Operation	60
9.1	Start, Stop, and Reset Commands	60
9.2	Command Override	60
9.3	Auto-start/Stop	60
9.3.1	Clock Mode	60
9.3.2	Timer Mode	60
9.4	PowerThrough	60
9.5	Emergency Mode	61
9.6	Auxiliary Trip	61
9.7	Typical Control Methods	61
9.8	Soft Start Methods	63
9.8.1	Constant Current	63
9.8.2	Constant Current with Current Ramp	63
9.8.3	Constant Current with Kickstart	64
9.8.4	Timed Voltage Ramp	64
9.8.5	Adaptive Control for Starting	65
9.8.5.1	Fine-tuning Adaptive Control	66
9.9	Stop Methods	66
9.9.1	Coast to Stop	66
9.9.2	Timed Voltage Ramp	66
9.9.3	Adaptive Control for Stopping	67
9.9.4	DC Brake	68
9.9.5	Soft Brake	69
9.10	Pump Clean	70
9.11	Reverse Direction Operation	70
9.12	Jog Operation	71
9.13	Inside Delta Operation	72

9.14	Secondary Motor Set	72
10 Programmable Parameters		74
10.1	Main Menu	74
10.2	Changing Parameter Values	74
10.3	Adjustment Lock	74
10.4	Parameter List	74
10.5	Parameter Group 1-** Motor Details	82
10.6	Parameter Group 2-** Motor Start/Stop	83
10.7	Parameter Group 3-** Motor Start/Stop-2	86
10.8	Parameter Group 4-** Auto-Start/Stop	89
10.9	Parameter Group 5-** Protection Levels	92
10.10	Parameter Group 6-** Protection Action	94
10.11	Parameter Group 7-** Inputs	100
10.12	Parameter Group 8-** Relay Outputs	104
10.13	Parameter Group 9-** Analog Output	106
10.14	Parameter Group 10-** Display	106
10.15	Parameter Group 11-** Pump Clean	110
10.16	Parameter Group 12-** Communication Card	111
10.17	Parameter Group 20-** Advanced	114
10.18	Parameter Groups 30-** to 36-**	116
10.19	Parameter Group 40-** Ground Fault	116
11 Troubleshooting		118
11.1	Protection Responses	118
11.2	Trip Messages	118
11.3	General Faults	129
12 Appendix		132
12.1	Symbols and Abbreviations	132

1 Introduction

1.1 Product Description

The VLT® Soft Starter MCD 600 is an advanced digital soft start solution for 11–1400 kW motors. The soft starters provide a complete range of motor and system protection features and are designed for reliable performance in the most demanding installation situations.

1.2 Document Version

This manual is regularly reviewed and updated. All suggestions for improvement are welcome.

Table 1: Document Version

Version	Remarks
AQ262141844215, version 0401	Updated with information about S3 models.

1.3 Additional Resources

Other resources are available to understand advanced soft starter functions and programming.

- Operating guides for operation with optional equipment.
- Installation guides for installing various accessories.
- WinStart Design Tool to help with selecting the right soft starter for an application.

Supplementary publications and manuals are available from www.danfoss.com under the sections *Service and support/Documentation*.

1.4 Approvals and Certifications

--	--	--

2 Safety

2.1 Safety Symbols

The following symbols are used in this manual:

⚠ D A N G E R ⚠

Indicates a hazardous situation which, if not avoided, will result in death or serious injury.

⚠ W A R N I N G ⚠

Indicates a hazardous situation which, if not avoided, could result in death or serious injury.

⚠ C A U T I O N ⚠

Indicates a hazardous situation which, if not avoided, could result in minor or moderate injury.

N O T I C E

Indicates a property damage message.

2.2 Qualified Personnel

Correct and reliable transport, storage, installation, operation, and maintenance are required for the trouble-free and safe operation of the soft starter. Only qualified personnel are allowed to install or operate this equipment.

Qualified personnel are defined as trained staff, who are authorized to install, commission, and maintain equipment, systems, and circuits in accordance with pertinent laws and regulations. Also, the qualified personnel must be familiar with the instructions and safety measures described in this manual.

2.3 Safety Precautions

Safety precautions cannot cover every potential cause of equipment damage, but can highlight common causes of damage. It is the installer's responsibility to:

- Read and understand all instructions in this manual before installing, operating, or maintaining the equipment.
- Follow good electrical practice including applying appropriate personal protective equipment.
- Seek advice before operating this equipment in a manner other than described in this manual.

N O T I C E

The VLT® Soft Starter MCD 600 is not user serviceable. The unit should only be serviced by authorized service personnel. Unauthorized tampering with the unit voids the product warranty.

⚠ W A R N I N G ⚠

PROPER GROUNDING

It is the responsibility of the installer of the soft starter to provide proper grounding and branch circuit protection according to local electrical safety codes. Not providing proper grounding and branch circuit protection may lead to death, personal injury, or equipment damage.

- Disconnect the soft starter from mains voltage before carrying out repair work.

⚠ W A R N I N G ⚠**UNINTENDED START**

When the soft starter is connected to AC mains, DC supply, or load sharing, the motor can start at any time. Unintended start during programming, service, or repair work can result in death, serious injury or property damage. The motor can start with an external switch, a fieldbus command, an input reference signal from the LCP, or after a cleared fault condition.

- Press [Off/Reset] on the LCP before programming parameters.
- Disconnect the soft starter from the mains.
- Completely wire and assemble the soft starter, motor, and any driven equipment before connecting the soft starter to AC mains, DC supply, or load sharing.
- Fit the power supply to the soft starter with an isolating switch and a circuit-breaking device (for example a power contactor) controllable through an external safety system (for example an emergency stop or a fault detector).

⚠ C A U T I O N ⚠**POWER FACTOR CORRECTION**

Connecting power factor correction capacitors to the output side will damage the soft starter.

- Do not connect power factor correction capacitors to the output of the soft starter. If static power factor correction is employed, it must be connected to the supply side of the soft starter.

⚠ C A U T I O N ⚠**SHORT CIRCUIT**

The VLT® Soft Starter MCD 600 is not circuit proof.

- After severe overload or short circuit, the operation of the MCD 600 should be fully tested by an authorized service agent.

⚠ C A U T I O N ⚠**MECHANICAL DAMAGE FROM UNEXPECTED RESTART**

The motor could restart after the causes of a shutdown are rectified, which may be dangerous for certain machines or installations.

- Ensure that appropriate arrangements are made against restarting after unscheduled stops of the motor.

⚠ W A R N I N G ⚠**SAFETY OF PERSONNEL**

The soft starter is not a safety device and does not provide electrical isolation or disconnection from the supply.

- If isolation is required, the soft starter must be installed with a main contactor.
- Do not rely on the start and stop functions for safety of personnel. Faults occurring in the mains supply, the motor connection, or the electronics of the soft starter can cause motor starts or stops.
- If faults occur in the electronics of the soft starter, a stopped motor may start. A temporary fault in the mains supply or loss of motor connection can also cause a stopped motor to start.
- To provide safety of personnel and equipment, control the isolation device through an external safety system.

N O T I C E

- Before changing any parameter settings, save the current parameter set to a file using MCD PC Software or the Save User Set function.

N O T I C E

- Use the Auto-start feature with caution. Read all the notes related to auto-start before operation.

Disclaimer

The examples and diagrams in this manual are included solely for illustrative purposes. The information contained in this manual is subject to change at any time and without prior notice. Responsibility or liability is never accepted for direct, indirect, or consequential damage resulting from the use or application of this equipment.

3 System Design

3.1 Feature List

Streamlined set-up process

- Configuration profiles for common applications.
- Built-in metering and inputs/outputs.

Easy-to-understand interface

- Multi-language menus and displays.
- Descriptive option names and feedback messages.
- Real-time performance graphs.

Supports energy efficiency

- IE3 compatible.
- 99% energy efficient when running.
- Soft start technology avoids harmonic distortion.

Extensive range of models

- 20–1250 A (nominal).
- 200–525 V AC.
- 380–690 V AC.
- Bypassed or continuous options.
- In-line or inside delta installation.

Extensive input and output options

- Remote control inputs (2 x fixed, 2 x programmable).
- Relay outputs (2 x fixed, 2 x programmable).
- Analog output.

Versatile starting and stopping options

- Scheduled start/stop.
- Adaptive control.
- Constant current.
- Current ramp.
- Pump clean.
- Timed voltage ramp soft stop.
- Coast to stop.
- DC brake.
- Soft brake.
- Reverse direction.

Customizable protection

- Motor overload.
- Excess start time.
- Undercurrent/overcurrent.
- Underpower/overpower.
- Undervoltage/overvoltage
- Current imbalance.

- Input trip.
- Motor thermistor.

Optional features for advanced applications

- Smart cards.
- Communication options:
 - DeviceNet.
 - EtherNet/IP.
 - **Modbus RTU.**
 - Modbus TCP.
 - PROFIBUS.
 - PROFINET.
- Ground fault protection.

3.2 Type Code

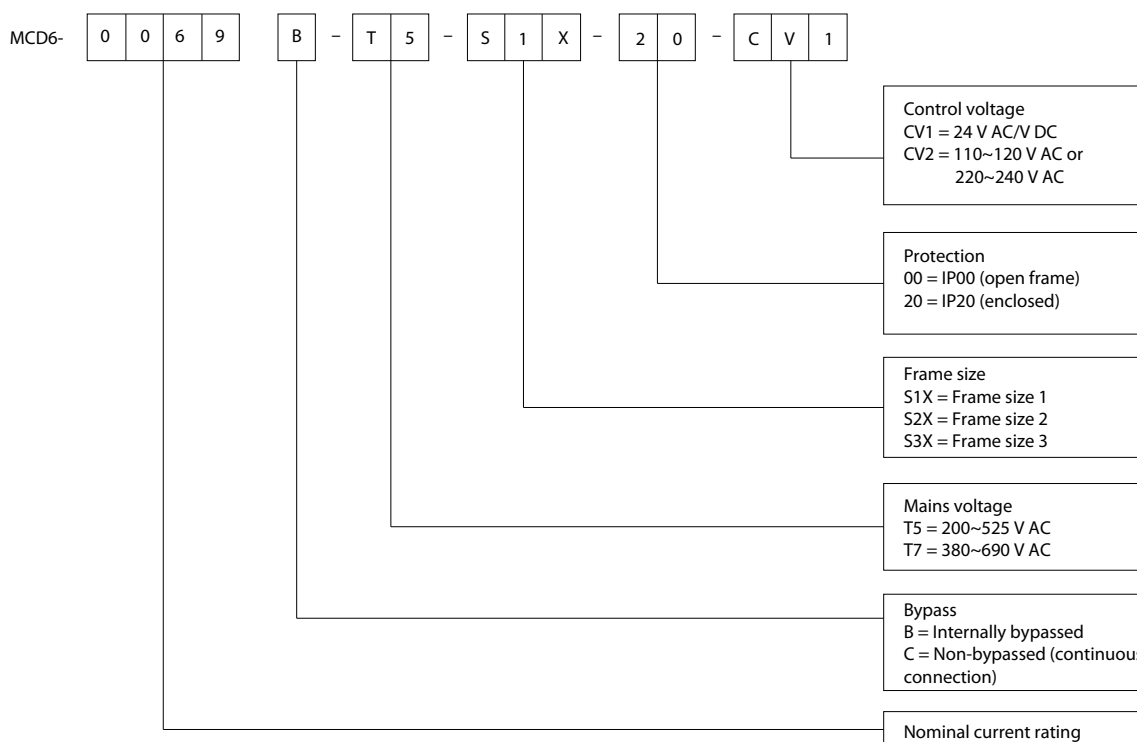

Illustration 1: Type Code String

3.3 Selection of Soft Starter Size

The size of the soft starter must match the motor and the application.

Select a soft starter that has a current rating at least equal to the motor's full load current rating (see motor nameplate) at the start duty.

The soft starter's current rating determines the maximum motor size it can be used with. The soft starter's rating depends on the number of starts per hour, the length and current level of the start, and the amount of time the soft starter is off (not passing current) between starts.

The soft starter's current rating is only valid when used in the conditions specified in the AC53 code. The soft starter may have a higher or lower current rating in different operating conditions.

3.4 Current Ratings (IEC Ratings)

NOTICE

Contact the local supplier for ratings under operating conditions not covered by these rating charts.

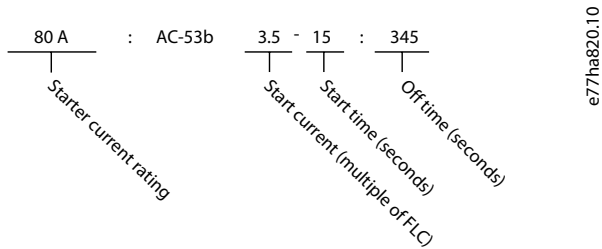

Illustration 2: AC53b Format (Bypassed Current Rating)

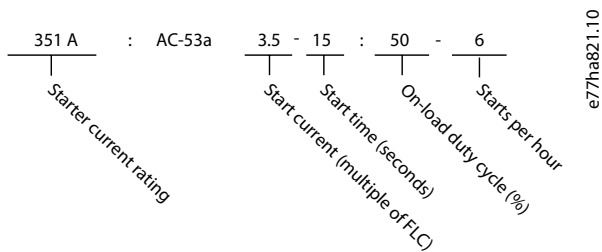

Illustration 3: AC53a Format (Non-bypassed Current Rating)

NOTICE

All ratings are calculated at an altitude of 1000 m (3280 ft) and an ambient temperature of 40 °C (104 °F).

Table 2: In-line Installation, Internal Bypassed, MCD6-0020B ~ MCD6-0042B

	3.0-10:350	3.5-15:345	4.0-10:350	4.0-20:340	5.0-5:355
MCD6-0020B	24	20	19	16	16
MCD6-0034B	42	34	34	27	31
MCD6-0042B	52	42	39	34	34

Table 3: In-line Installation, Internal Bypassed, MCD6-0063B ~ MCD6-1250B

	3.0-10:590	3.5-15:585	4.0-10:590	4.0-20:580	5.0-5:595
MCD6-0063B	64	62	60	50	53
MCD6-0069B	69	69	69	62	64
MCD6-0086B	105	86	84	68	76
MCD6-0108B	115	107	104	86	95
MCD6-0129B	135	129	126	103	115
MCD6-0144B	184	143	139	115	127
MCD6-0171B	200	170	165	138	150
MCD6-0194B	229	194	187	157	170

	3.0-10:590	3.5-15:585	4.0-10:590	4.0-20:580	5.0-5:595
MCD6-0244B	250	244	230	200	202
MCD6-0287B	352	285	277	234	257
MCD6-0323B	397	322	311	262	288
MCD6-0410B	410	410	410	379	400
MCD6-0527B	550	526	505	427	462
MCD6-0579B	580	578	554	469	507
MCD6-0654B	835	654	630	535	592
MCD6-0736B	940	736	708	603	663
MCD6-0950B	1070	950	905	785	834
MCD6-1154B	1230	1154	1090	959	989
MCD6-1250B	1250	1250	1250	1155	1250

Table 4: In-line Installation, Non-bypassed, MCD6-0160C~MCD6-1134C

	3.0-10:50-6	3.5-15:50-6	4.0-10:590	4.0-20:50-6	5.0-5:50-6
MCD6-0160C	190	160	151	144	133
MCD6-0215C	260	215	205	180	192
MCD6-0275C	341	275	266	230	252
MCD6-0343C	404	343	322	296	291
MCD6-0448C	474	448	457	418	470
MCD6-0590C	735	590	572	492	542
MCD6-0667C	830	667	645	557	609
MCD6-0839C	1025	839	805	710	751
MCD6-0979C	1170	979	934	838	862
MCD6-1134C	1220	1134	1109	964	1075

N O T I C E

Models MCD6-0590C~MCD6-1134C must be installed with an external bypass contactor to achieve the bypassed current ratings.

Table 5: In-line Installation, External Bypassed, MCD6-0590C~MCD6-1134C

	3.0-10:50-6	3.5-15:50-6	4.0-10:590	4.0-20:50-6	5.0-5:50-6
MCD6-0590C	835	732	716	593	695
MCD6-0667C	940	822	803	667	776
MCD6-0839C	1210	1067	1033	874	982
MCD6-0979C	1430	1307	1252	1076	1170
MCD6-1134C	1620	1620	1616	1309	1620

Table 6: Inside Delta Installation, Internal Bypassed, MCD6-0020B~MCD6-0042B

	3.0-10:350	3.5-15:345	4.0-10:350	4.0-20:340	5.0-5:355
MCD6-0020B	36	30	29	24	24
MCD6-0034B	63	51	51	41	47
MCD6-0042B	78	62	59	51	51

Table 7: Inside Delta Installation, Internal Bypassed, MCD6-0063B~MCD6-1250B

	3.0-10:590	3.5-15:585	4.0-10:590	4.0-20:580	5.0-5:595
MCD6-0063B	96	93	90	75	80
MCD6-0069B	104	104	104	93	96
MCD6-0086B	158	129	126	102	114
MCD6-0108B	173	161	156	129	143
MCD6-0129B	203	194	189	155	173
MCD6-0144B	276	215	209	173	191
MCD6-0171B	300	255	248	207	225
MCD6-0194B	344	291	281	236	255
MCD6-0244B	375	366	345	300	303
MCD6-0287B	528	428	415	351	386
MCD6-0323B	596	484	466	393	433
MCD6-0410B	615	615	615	568	600
MCD6-0527B	825	789	758	640	694
MCD6-0579B	870	868	832	704	760
MCD6-0654B	1253	981	945	803	888
MCD6-0736B	1410	1104	1062	905	995
MCD6-0950B	1605	1425	1358	1178	1251
MCD6-1154B	1845	1731	1635	1439	1484
MCD6-1250B	1875	1875	1875	1733	1875

Table 8: Inside Delta Installation, Non-bypassed, MCD6-0160C~MCD6-1134C

	3.0-10:50-6	3.5-15:50-6	4.0-10:50-6	4.0-20:50-6	5.0-5:50-6
MCD6-0160C	285	240	227	216	200
MCD6-0215C	390	323	306	270	288
MCD6-0275C	512	413	399	345	378
MCD6-0343C	606	515	483	444	437
MCD6-0448C	711	672	686	627	705

	3.0-10:50-6	3.5-15:50-6	4.0-10:50-6	4.0-20:50-6	5.0-5:50-6
MCD6-0590C	1103	885	858	738	813
MCD6-0667C	1245	1001	968	836	914
MCD6-0839C	1538	1259	1208	1065	1127
MCD6-0979C	1755	1469	1401	1257	1293
MCD6-1134C	1830	1701	1664	1446	1613

Table 9: Inside Delta Installation, External bypassed, MCD6-0590C~MCD6-1134C

	3.0-10:50-6	3.5-15:50-6	4.0-10:50-6	4.0-20:50-6	5.0-5:50-6
MCD6-0590C	1253	1098	1074	890	1043
MCD6-0667C	1410	1233	1205	1001	1164
MCD6-0839C	1815	1601	1550	1311	1473
MCD6-0979C	2145	1961	1878	1614	1755
MCD6-1134C	2430	2430	2424	1964	2430

3.5 Current Ratings (NEMA Ratings)

NOTICE

Contact the local supplier for ratings under operating conditions not covered by these rating charts.

NOTICE

All ratings are calculated at an altitude of 1000 m (3280 ft) and an ambient temperature of 50 °C (122 °F).

Table 10: Current Ratings, NEMA, at Normal and Heavy Overload, In-line Installation, Bypassed

	Normal 350%, 30 s, 4 starts per hour				Heavy 450%, 30 s, 4 starts per hour			
	A	hp @240 V AC	hp @480 V AC	hp @600 V AC	A	hp @240 V AC	hp @480 V AC	hp @600 V AC
MCD6-0020B	17	5	10	15	14	3	10	10
MCD6-0034B	28	10	20	25	22	7.5	15	20
MCD6-0042B	35	10	25	30	28	10	20	25
MCD6-0063B	52	15	40	40	40	10	25	30
MCD6-0069B	59	20	40	50	46	15	30	40
MCD6-0086B	77	25	60	60	52	15	40	50
MCD6-0108B	81	30	60	75	65	20	50	60
MCD6-0129B	99	30	75	100	77	25	60	75
MCD6-0144B	124	40	100	100	96	30	75	75
MCD6-0171B	131	50	100	125	104	40	75	100
MCD6-0194B	156	60	125	150	124	40	100	100

	Normal 350%, 30 s, 4 starts per hour				Heavy 450%, 30 s, 4 starts per hour			
MCD6-0244B	195	75	150	200	156	60	125	150
MCD6-0287B	240	75	200	200	180	60	150	150
MCD6-0323B	261	100	200	250	203	75	150	200
MCD6-0410B	377	150	300	350	302	100	250	300
MCD6-0527B	414	150	350	450	321	125	250	300
MCD6-0579B	477	200	400	500	361	150	300	350
MCD6-0654B	515	200	450	500	414	150	300	350
MCD6-0736B	590	200	500	600	480	200	400	500
MCD6-0950B	797	300	600	800	620	250	500	600
MCD6-1154B	985	400	800	1000	768	300	600	800
MCD6-1250B	1180	500	900	1200	904	350	700	900
MCD6-0160C								
MCD6-0215C								
MCD6-0275C								
MCD6-0343C								
MCD6-0448C								
MCD6-0590C	551	200	450	500	429	150	350	450
MCD6-0667C	634	250	500	600	493	200	400	500
MCD6-0839C	882	350	700	900	686	250	500	700
MCD6-0979C	1100	450	900	1100	864	350	700	900
MCD6-1134C	1320	500	1100	1300	1030	450	800	1000

Table 11: Current Ratings, NEMA, at Normal and Heavy Overload, In-line Installation, Non-bypassed

	Normal 350%, 30 s, 4 starts per hour				Heavy 450%, 30 s, 4 starts per hour			
	A	hp @240 V AC	hp @480 V AC	hp @600 V AC	A	hp @240 V AC	hp @480 V AC	hp @600 V AC
MCD6-0160C	146	50	100	150	118	40	75	100
MCD6-0215C	176	60	125	150	143	50	100	150
MCD6-0275C	233	75	150	200	185	60	150	150
MCD6-0343C	306	100	250	300	246	75	200	250
MCD6-0448C	354	125	250	350	335	125	250	350
MCD6-0590C	480	200	400	500	382	150	300	400
MCD6-0667C	576	200	450	600	431	150	350	450
MCD6-0839C	722	300	600	700	590	200	500	600

	Normal 350%, 30 s, 4 starts per hour				Heavy 450%, 30 s, 4 starts per hour			
	A	hp @240 V AC	hp @480 V AC	hp @600 V AC	A	hp @240 V AC	hp @480 V AC	hp @600 V AC
MCD6-0979C	864	350	700	900	722	300	600	700
MCD6-1134C	966	400	800	1000	784	300	600	800

3.6 Dimensions and Weight

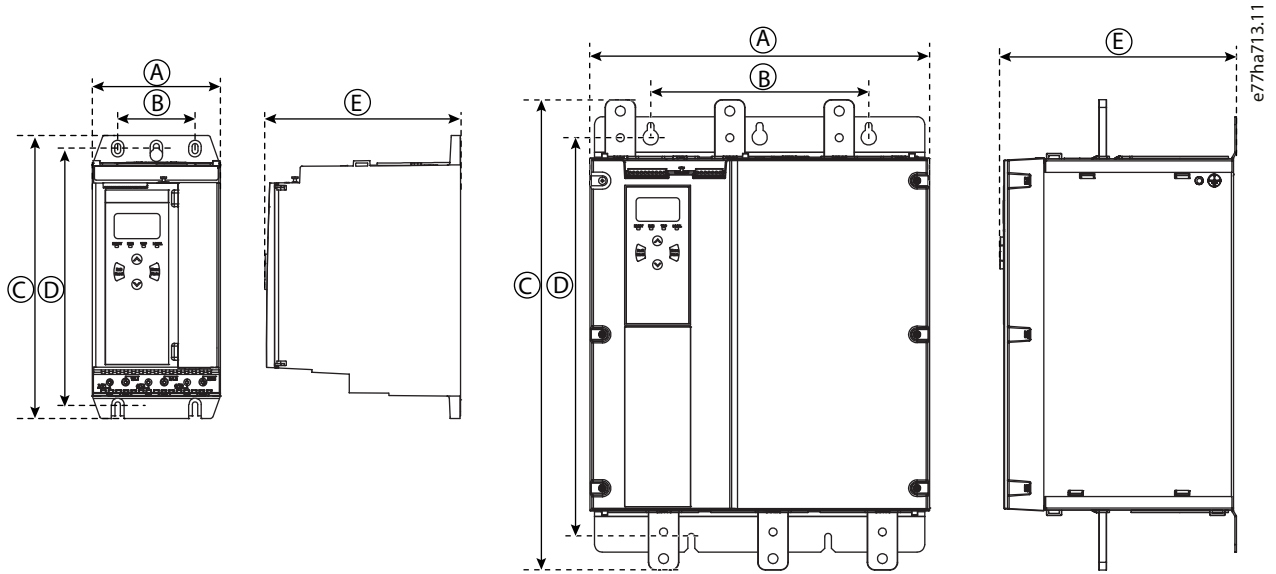

Illustration 4: Dimensions and Weight

Table 12: Dimensions and Weight

	Width [mm (in)]		Height [mm (in)]		Depth [mm (in)]	Weight [kg (lb)]
	A	B	C	D	E	
MCD6-0020B	152 (6.0)	92 (3.6)	336 (13.2)	307 (12.1)	231 (9.1)	4.8 (10.7)
MCD6-0034B						
MCD6-0042B						
MCD6-0063B						4.9 (10.9)
MCD6-0069B						
MCD6-0086B						
MCD6-0108B						
MCD6-0129B	5.5 (12.1)					
MCD6-0144B						
MCD6-0171B						
MCD6-0194B						
MCD6-0244B						
MCD6-0287B	216 (8.5)	180 (7.1)	495 (19.5)	450 (17.7)	243 (9.6)	12.7 (28)

	Width [mm (in)]		Height [mm (in)]		Depth [mm (in)]	Weight [kg (lb)]
MCD6-0323B						19 (41.9)
MCD6-0410B						
MCD6-0527B						
MCD6-0579B						
MCD6-0654B	447 (17.6)	287 (11.3)	618 (24.3)	525 (20.7)	310 (12.3)	51 (112.4)
MCD6-0736B						
MCD6-0950B						
MCD6-1154B						
MCD6-1250B						
MCD6-0160C	216 (17.6)	180 (11.3)	495 (19.5)	450 (17.7)	245 (12.3)	12.2 (26.9)
MCD6-0215C						
MCD6-0275C						
MCD6-0343C						
MCD6-0448C						
MCD6-0590C	447 (17.6)	287 (11.3)	618 (24.3)	525 (20.7)	310 (12.3)	47 (103.6)
MCD6-0667C						
MCD6-0839C						
MCD6-0979C						
MCD6-1134C						

3.7 Physical Installation/Cooling Clearances

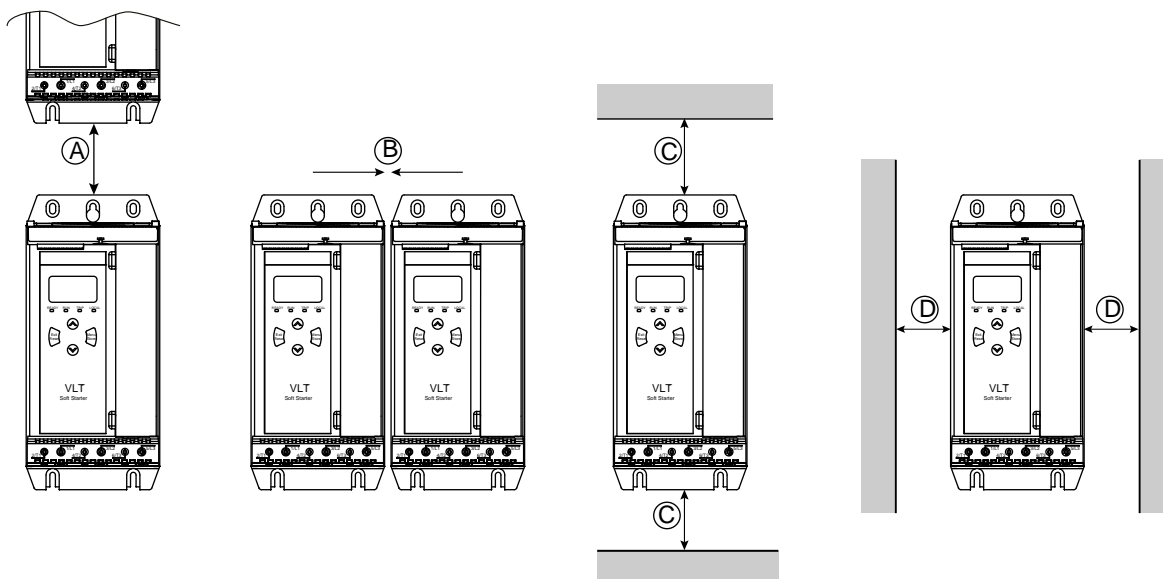

177HA714.10

Illustration 5: Clearances

Table 13: Cooling Clearances

Clearance between soft starters		Clearance to solid surfaces	
A [mm (in)]	B [mm (in)]	C [mm (in)]	D [mm (in)]
>100 (3.9)	>10 (0.4)	>100 (3.9)	>10 (0.4)

3.8 Accessories

3.8.1 Expansion Cards

The VLT® Soft Starter MCD 600 offers expansion cards for users requiring additional inputs and outputs or advanced functionality. Each MCD 600 can support a maximum of 1 expansion card.

3.8.1.1 Smart Card

The smart card has been designed to support integration with pumping applications and provides the following additional inputs and outputs:

- 3 x digital inputs.
- 3 x 4–20 mA transducer inputs.
- 1 x RTD input.
- 1 x USB-B port.
- Remote LCP connector.

Ordering number: 175G0133

3.8.1.2 Communication Expansion Cards

The VLT® Soft Starter MCD 600 supports network communication via easy-to-install communication expansion cards. Each communication card includes a remote LCP 601 connector port.

Table 14: Fieldbus Expansion Cards with Ordering Numbers

Option Card	Ordering Number
VLT® Soft Starter MCD 600 Modbus RTU	175G0127
VLT® Soft Starter MCD 600 PROFIBUS	175G0128
VLT® Soft Starter MCD 600 DeviceNet	175G0129
VLT® Soft Starter MCD 600 Modbus TCP	175G0130
VLT® Soft Starter MCD 600 EtherNet/IP	175G0131
VLT® Soft Starter MCD 600 PROFINET	175G0132
VLT® Soft Starter MCD 600 Pump Application	175G0133

3.8.1.3 Ground Fault Protection

The MCD 600 can detect ground current and trip before the equipment is damaged.

Ground fault protection requires a 1000:1 or 2000:1 5 VA current transformer (not supplied). Ground fault protection is available as an option with specific versions of the Modbus RTU, Modbus TCP, EtherNet/IP, and PROFINET expansion cards.

3.8.2 Remote LCP 601

The VLT® Soft Starter MCD 600 soft starters can be used with a remote LCP mounted up to 3 m (9.8 ft) away from the soft starter. Each expansion card includes an LCP connection port, or a dedicated LCP connector card is available.

Ordering number for the Remote LCP 601 expansion card: 175G0134.

3.8.3 Finger Guard Kit

Finger guards may be specified for personal safety. Finger guards fit over the soft starter terminals to prevent accidental contact with live terminals. Finger guards provide IP20 protection when used with cable of diameter 22 mm or greater.

Finger guards are compatible with models:

- Frame size S2
 - Ordering number: 175G0186
- Frame size S3
 - 175G0202

3.8.4 Soft Starter Management Software

The VLT® Soft Starter MCD 600 has an installed USB flash interface. The USB flash must be formatted to FAT32 format. To format the flash, follow the instructions on a PC when connecting a standard flash stick (minimum 4 MB) to a USB port. VLT® Motion Control Tool MCT 10 transfers the set-up files to the USB flash stick. To load the set-up files to the soft starter, use the LCP as described in [6.7.1 Save and Load Procedure](#).

The VLT® Motion Control Tool MCT 10 can help manage the soft starter. Contact the local supplier for more information.

Documentation for the VLT® Motion Control Tool MCT 10 can be downloaded from www.danfoss.com under the sections *Service & Support/Downloads*.

3.9 Main Contactor

A main contactor is recommended to protect the soft starter from voltage disturbances on the network while stopped. Select a contactor with an AC3 rating greater than or equal to the FLC rating of the connected motor.

Use the main contactor output (13, 14) to control the contactor.

For wiring of the main contactor, see [Illustration 17](#) in [5.10.1 Internally Bypassed Installation](#).

⚠ WARNING ⚠

SHOCK HAZARD

When the soft starter is wired in inside delta configuration, it results in a portion of the motor windings being connected to line power at all times (even when the soft starter is switched off). This situation may cause death or serious personal injury.

- Always install a main contactor or shunt trip circuit breaker when connecting the soft starter in inside delta configuration.

3.10 Circuit Breaker

A shunt trip circuit breaker may be used instead of a main contactor to isolate the motor circuit if a soft starter trips. The shunt trip mechanism must be powered from the supply side of the circuit breaker or from a separate control supply.

3.11 External Bypass Contactor

Models MCD6-0590C~MCD6-1134C can be installed with an external bypass contactor. Bypassing the soft starter increases the soft starter's maximum current rating and allows the motor to be started direct on-line (across the line) if the soft starter is damaged.

- To bypass the soft starter during run, use an external bypass contactor with an AC1 rating.
- To bypass the soft starter completely (to allow direct on-line starting if the starter is damaged), use an external bypass contactor with an AC3 rating.

N O T I C E

Models MCD6-0160C~MCD6-0448C are not suitable for installation with an external bypass contactor.

3.12 Power Factor Correction

If power factor correction is used, use a dedicated contactor to switch in the capacitors.

To use the VLT® Soft Starter MCD 600 to control power factor correction, connect the PFC contactor to a programmable relay set to Run. When the motor reaches full speed, the relay closes and power factor correction is switched in.

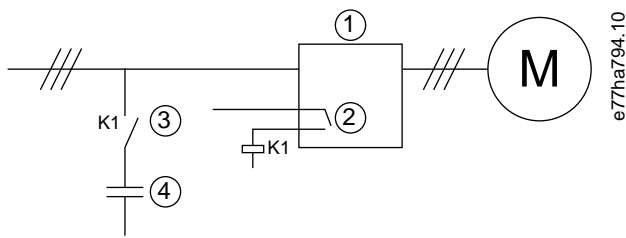

Illustration 6: Connection Diagram

1	Soft starter	3	Power factor correction contactor
2	Programmable output (set=Run)	4	Power factor correction

CAUTION

EQUIPMENT DAMAGE

Connecting power factor correction capacitors to the output side damages the soft starter.

- Always connect power factor correction capacitors to the input side of the soft starter.
- Do not use the soft starter relay output to switch in power factor correction directly.

3.13 Short-circuit Protection Devices

When designing motor circuit protection schemes, the IEC 60947-4-1 standard on soft starters and contactors defines 2 types of coordination regarding soft starters:

- Type 1 coordination.
- Type 2 coordination.

3.13.1 Type 1 Coordination

Type 1 coordination requires that, if there is a short circuit on the output side of a soft starter, the fault must be cleared without risk of injury to personnel and damage to installations. There is no requirement that the soft starter must remain operational after the fault. For the soft starter to become operational again, repair and replacement of parts are required.

HRC fuses (such as Ferraz/Mersen AJT fuses) can be used for Type 1 coordination according to the IEC 60947-4-2 standard.

3.13.2 Type 2 Coordination

Type 2 coordination requires that, if there is a short circuit on the output side of a soft starter, the fault must be cleared without risk of injury to personnel or damage to the soft starter.

Type 2 coordination has the advantage that, after the fault is cleared, authorized personnel can replace the blown fuses and check contactors for any welding. The soft starter is then operational again.

Semiconductor fuses for Type 2 circuit protection are extra to HRC fuses or MCCBs that form part of the motor branch circuit protection.

CAUTION

DC BRAKE

A high brake torque setting can result in peak currents up to motor DOL being drawn while the motor is stopping.

- Ensure that protection fuses installed in the motor branch circuit are selected appropriately.

CAUTION

NO BRANCH CIRCUIT PROTECTION

Integral solid-state short-circuit protection does not provide branch circuit protection.

- Provide branch circuit protection in accordance with the National Electrical Code and any additional local codes.

3.14 IEC Coordination with Short-circuit Protection Devices

These fuses were selected based on a start current of 300% FLC for 10 s.

Table 15: Models MCD6-0020B~MCD6-0579B

	Nominal rating [A]	SCR I ² t (A ² s)	Type 1 coordination 480 V AC, 65 kA Bussmann NH fuse links	Type 2 coordination 690 V AC, 65 kA Bussmann DIN 43 653
MCD6-0020B	24	1150	40NHG000B	170M3010
MCD6-0034B	42	7200	63NHG000B	170M3013
MCD6-0042B	52		80NHG000B	
MCD6-0063B	64	15000	100NHG000B	170M3014
MCD6-0069B	69			
MCD6-0086B	105	80000	160NHG00B	170M3015
MCD6-0108B	115			
MCD6-0129B	135	125000		170M3016
MCD6-0144B	184	320000	250NHG2B	170M3020
MCD6-0171B	200			
MCD6-0194B	229		315NHG2B	
MCD6-0244B	250			170M3021
MCD6-0287B	352	202000	355NHG2B	170M6009
MCD6-0323B	397		400NHG2B	
MCD6-0410B	410	320000	425NHG2B	170M6010
MCD6-0527B	550	781000	630NHG3B	170M6012
MCD6-0579B	579			

Table 16: Models MCD6-0654B~MCD6-1250B/MCD6-0590C~MCD6-1134C, Bypassed Installation

	Nominal rating (A)	SCR I ² t (A ² s)	Type 1 coordination 500 V AC, 100 kA	Type 2 coordination 690 V AC, 100 kA
MCD6-0654B	835	2530000	1000NHG4G	170M6016
MCD6-0736B	940			170M6017
MCD6-0950B	1070		1200NHG4G	Not available
MCD6-1154B	1230	3920000	OFAA5GG1250	
MCD6-1250B	1250	7220000		170M6019
MCD6-0590C	835	2530000	1000NHG4G	170M6016
MCD6-0667C	940			170M6017
MCD6-0839C	1210		OFAA5GG1250	Not available
MCD6-0979C	1430	3920000	OFAA5GG1600	
MCD6-1134C	1620	7220000		170M6021 (at 500 V AC)

Table 17: Models MCD6-0160C~MCD6-1134C, Continuous Connection

	Nominal rating (A)	SCR I ² t (A ² s)	Type 1 coordination 500 V AC, 100 kA	Type 2 coordination 690 V AC, 100 kA
MCD6-0654B	190	320000	250NHG2B	170M3020
MCD6-0736B	260		315NHG2B	170M3021
MCD6-0950B	350	202000	355NHG2B	170M6009
MCD6-1154B	475	320000	425NHG2B	170M6010
MCD6-1250B	565	781000	630NHG3B	170M6011
MCD6-0590C	735	2530000	1000NHG4G	170M6016
MCD6-0667C	830			
MCD6-0839C	1025		1200NHG4G	170M6017
MCD6-0979C	1170	3920000	OFAA5GG1250	Not available
MCD6-1134C	1220	7220000		170M6019

3.15 UL Coordination with Short-circuit Protection Devices

3.15.1 Standard Fault Short Circuit

3.15.1.1 Models MCD6-0020B~MCD6-0579B

Suitable for use on a circuit capable of delivering not more than the stated level of amperes (symmetrical rms), 600 V AC maximum. These nominal ratings are based on a start current of 300% FLC for 10 s.

Table 18: Maximum Fuse Rating [A] - Standard Fault Short-Circuit Current

Model	Nominal rating [A]	3 cycle short cct rating @600 V AC ⁽¹⁾
MCD6-0020B	24	5 kA
MCD6-0034B	42	
MCD6-0042B	52	10 kA
MCD6-0063B	64	
MCD6-0069B	69	
MCD6-0086B	105	
MCD6-0108B	120	
MCD6-0129B	135	
MCD6-0144B	184	18 kA
MCD6-0171B	225	
MCD6-0194B	229	
MCD6-0244B	250	
MCD6-0287B	352	
MCD6-0323B	397	

Model	Nominal rating [A]	3 cycle short cct rating @600 V AC ⁽¹⁾
MCD6-0410B	410	30 kA
MCD6-0527B	550	
MCD6-0579B	580	

¹ Suitable for use in a circuit with the prospective current noted, when protected by any listed fuses or listed circuit breakers sized according to the NEC.

3.15.1.2 Models MCD6-0654B~MCD6-1250B & MCD6-0590C~MCD6-1134C

Suitable for use on a circuit capable of delivering up to the stated fault current, when protected by the specified circuit breaker, or by a class L fuse sized according to the NEC.

These nominal ratings are based on start current of 300% FLC for 10 s for models MCD6-0654B~MCD6-1250B and start current of 300% at 50% duty for models MCD6-0590C~MCD6-1134C.

Table 19: Maximum Fuse Rating [A] - Standard Fault Short-Circuit Current

Model	Nominal rating [A]	@480 V AC/600 V AC		@480 V AC
		Fault current rating [kA]	Fuse rating [A]	Circuit breaker [A]
MCD6-0654B	835	42	1350	1200
MCD6-0736B	940			
MCD6-0950B	1070			
MCD6-1154B	1230	85	2500	1200
MCD6-1250B	1250			
MCD6-0590C	735	42	1350	1200
MCD6-0667C	830			
MCD6-0839C	1025			
MCD6-0979C	1170	85	2500	1200
MCD6-1134C	1220			

3.15.2 High Fault Short-circuit Current Ratings

Suitable for use on a circuit capable of delivering up to the stated fault current, when protected by the specified circuit breaker, or by a class L fuse sized according to the NEC.

These nominal ratings are based on start current of 300% FLC for 10 s.

- Circuit breakers with model codes beginning with HFD/HJD/HKD/HLD are from Eaton.
- Circuit breakers with model codes beginning with SELA/SFLA/SGLA are from GE.
- Circuit breakers with model codes beginning with UTS are from LS Electric.

N O T I C E

Models MCD6-0160C~MCD6-0448C are not UL Listed.

Table 20: Maximum Fuse Rating [A] - High Fault Short-circuit Current

Model	Nominal rating [A]	@480 V AC			
		Fault current rating [kA]	Fuse rating [A]	Fuse class	Circuit breaker rating [A]
MCD6-0020B	24	65	30	Any (J, T, K-1, RK1, RK5)	HFD3030 (30) SELA36AT0060 (60) UTS150H-xxU-040 (40)
MCD6-0034B	42		50		HFD3050 (50) SELA36AT0060 (60) UTS150H-xxU-050 (50)
MCD6-0042B	52		60		HFD3060 (60) SELA36AT0060 (60) UTS150H-xxU-060 (60)
MCD6-0063B	64		80		HFD3100 (100) SELA36AT0150 (150) UTS150H-xxU-100 (100 A)
MCD6-0069B	69		80		HFD3100 (100) SELA36AT0150 (150) UTS150H-xxU-100 (100)
MCD6-0086B	105	125	125	J, T, K-1, RK1	HFD3125 (125) SELA36AT0150 (150) UTS150H-xxU-125 (125)
MCD6-0108B	115		125		HFD3125 (125) SELA36AT0150 (150) UTS150H-xxU-125 (125)
MCD6-0129B	135		150		HFD3150 (150) SELA36AT0150 (150) UTS150H-xxU-150 (150)
MCD6-0144B	184		200		J, T
MCD6-0171B	225	225	HJD3250 (250) SFLA36AT0250 (250) UTS250H-xxU-250 (250)		
MCD6-0194B	229	250	HJD3250 (250) SFLA36AT0250 (250) UTS250H-xxU-250 (250)		
MCD6-0244B	250	300	HKD3300 (300) SFLA36AT0400 (400) UTS400H-xxU-300 (300)		

Model	Nominal rating [A]	@480 V AC			
		Fault current rating [kA]	Fuse rating [A]	Fuse class	Circuit breaker rating [A]
MCD6-0287	352		400	Any (J, T, K-1, RK1, RK5)	HLD3400 (400) SFLA36AT0600 (600) UTS400H-xxU-400 (400)
MCD6-0323B	397		450		HLD3400 (400) SFLA36AT0600 (600) UTS400H-xxU-400 (400)
MCD6-0410B	410		450		HLD3600 (600) SFLA36AT0600 (600) UTS600H-xxU-600 (600)
MCD6-0527B	550		600		HLD3600 (600) SFLA36AT0600 (600) UTS800H-xxU-800 (800)
MCD6-0579B	580		600		HLD3600 (600) SGLA36AT0600 (600) UTS800H-NGO-800 (800)

4 Specifications

4.1 Supply

Mains voltage (L1, L2, L3)

MCD6-xxxxB-T5 200–525 V AC ($\pm 10\%$)

MCD6-xxxxB-T7 380–690 V AC ($\pm 10\%$)

Control voltage (A7, A8, A9)

MCD6-xxxxB-xx-CV2 (A8, A9) 110–120 V AC (+10%/-15%), 600 mA

MCD6-xxxxB-xx-CV2 (A7, A9) 220–240 V AC (+10%/-15%), 600 mA

MCD6-xxxxB-xx-CV1 (A8, A9) 24 V AC/V DC ($\pm 20\%$), 2.8 A

Mains frequency 50–60 Hz (± 5 Hz)

Rated insulation voltage 690 V AC

Rated impulse withstand voltage 6 kV

Form designation Bypassed or continuous, semiconductor motor starter form 1

4.2 Short-circuit Capability

Coordination with semiconductor fuses Type 2

Coordination with HRC fuses Type 1

4.3 Electromagnetic Capability (Compliant with EU Directive 2014/35/EU)

EMC Immunity IEC 60947-4-2

EMC Emissions IEC 60947-4-2 Class B

4.4 Inputs

Input rating Active 24 V DC, 8 mA approximately

Motor thermistor (TER-05, TER-06) Trip >3.6 k Ω , reset <1.6 k Ω

4.5 Outputs

Relay outputs 10 A @ 250 V AC resistive, 5 A @ 250 V AC AC15 pf 0.3

Main contactor (13, 14) Normally open

Bypass contactor (03, 04) Normally open

Relay output A (21, 22, 23) Changeover

Relay output B (33, 34) Normally open

Analog output (AO-07, AO-08)

Maximum load 600 Ω (12 V DC @ 20 mA)

Accuracy $\pm 5\%$

4.6 Environmental

Operating temperature -10 to +60 °C (14–140 °F), above 40 °C (104 °F) with derating

Storage temperature -25 to +60 °C (-13 to +140 °F)

Operating altitude 0–1000 m (0–3280 ft), above 1000 m (3280 ft) with derating

Humidity 5–95% relative humidity

Pollution degree Pollution degree 3

Vibration IEC 60068-2-6

Protection

MCD6-0020B~MCD6-0129B IP20

MCD6-0144B~MCD6-1250B IP00

MCD6-0160C~MCD6-1134C

IP00

4.7 Heat Dissipation

During start	4.5 W per ampere
During run (bypassed)	
MCD6-0020B~MCD6-0042B	≤ 35 W approximately
MCD6-0063B~MCD6-0129B	≤ 50 W approximately
MCD6-0144B~MCD6-0244B	≤ 120 W approximately
MCD6-0287B~MCD6-0579B	≤ 140 W approximately
MCD6-0654B~MCD6-1250B	≤ 180 W approximately
During run (non-bypassed)	
MCD6-0160C~MCD6-1134C	4.5 W per ampere

4.8 Motor Overload Protection

The default settings of *parameters 1-4 to 1-6* provide motor overload protection. Class 10, trip current 105% of FLA (full load amperage) or equivalent

4.9 Certification

CCC	GB 14048.6
CE	EN 60947-4-2
UL/C-UL	UL 508
UL	UL 60947-4-2
MCD6-0020B~MCD6-1250B	UL Listed
MCD6-0590C~MCD6-1134C	UL Listed
Marine	
Lloyds Marine No 1 specification	All models
ABS: 2010 Steel Vessels Rules	MCD6-0654B~MCD6-1250B & MCD6-0590C~MCD6-1134C
RCM	IEC 60947-4-2

4.10 Operational Life (Internal Bypass Contacts)

Expected operational lifetime	100000 operations
-------------------------------	-------------------

5 Installation

5.1 Safety Instructions

See [2.3 Safety Precautions](#) for general safety instructions.

⚠ WARNING ⚠

INDUCED VOLTAGE

Induced voltage from output motor cables that run together can charge equipment capacitors, even with the equipment turned off and locked out. Failure to run output motor cables separately or to use shielded cables could result in death or serious injury.

- Run output motor cables separately.
- Use shielded cables.

⚠ WARNING ⚠

UNINTENDED START

When the soft starter is connected to AC mains, DC supply, or load sharing, the motor can start at any time. Unintended start during programming, service, or repair work can result in death, serious injury or property damage. The motor can start with an external switch, a fieldbus command, an input reference signal from the LCP, or after a cleared fault condition.

- Press [Off/Reset] on the LCP before programming parameters.
- Disconnect the soft starter from the mains.
- Completely wire and assemble the soft starter, motor, and any driven equipment before connecting the soft starter to AC mains, DC supply, or load sharing.
- Fit the power supply to the soft starter with an isolating switch and a circuit-breaking device (for example a power contactor) controllable through an external safety system (for example an emergency stop or a fault detector).

5.2 Command Source

Start and stop the soft starter via the digital inputs, remote LCP 601, communication network, smart card, or scheduled auto-start/stop. Set up the command source via *Set-up Tools* or via *parameter 1-1 Command Source*.

If the remote LCP is installed, the [CMD/Menu] key provides shortcut access to the Command Source function in *Setup Tools*.

5.3 Setting up the Soft Starter

Procedure

1. Mount the soft starter, see [3.7 Physical Installation/Cooling Clearances](#).
2. Connect control wiring, see [5.4.1 Input Terminals](#).
3. Apply control voltage to the soft starter.
4. Configure the application (listed in the Quick Set-up):
 - a. Press [Menu].
 - b. Press [Menu/Store] to open the Quick Set-up menu.
 - c. Scroll through the list to find the application.
 - d. Press [Menu/Store] to begin the configuration process, see [5.11 Quick Set-up](#).
5. Configure the application (not listed in the Quick Set-up):
 - a. Press [Back] to return to the Menu.
 - b. Press [▼] to scroll to the Main Menu and press [Menu/Store].
 - c. Scroll to *Motor Details*, press [Menu/Store] twice, and edit *parameter 1-2 Motor Full Load Current*.
 - d. Set *parameter 1-2 Motor Full Load Current* to match the motor full load current (FLC).
 - e. Press [Menu/Store] to save the setting.
6. Press [Back] repeatedly to close the Main Menu.
7. (Optional) Use the built-in simulation tools to check that the control wiring is connected correctly, see [6.5 Run Simulation](#).
8. Power off the soft starter.
9. Connect the motor cables to the soft starter output terminals 2/T1, 4/T2, 6/T3.
10. Connect mains supply cables to the soft starter input terminals 1/L1, 3/L2, 5/L3, see [5.7 Power Terminations](#).

The soft starter is now ready to control the motor.

5.4 Inputs

⚠ CAUTION ⚠

The control inputs are powered by the soft starter. Do not apply external voltage to the control input terminals.

NOTICE

Cables to the control inputs must be segregated from mains voltage and motor cabling.

5.4.1 Input Terminals

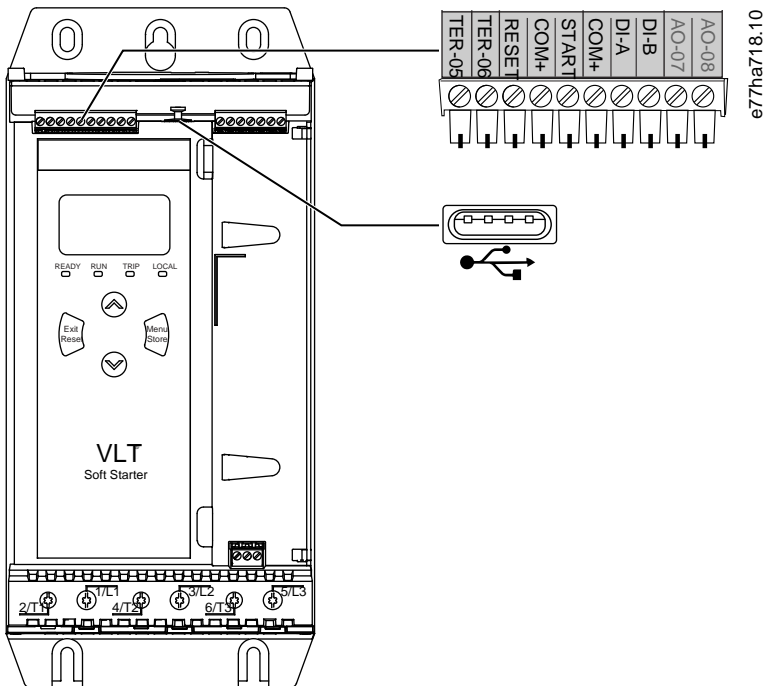



Illustration 7: Input Terminals

TER-05, TER-06	Motor thermistor input	DI-A, COM+	Programmable input A (default = Input trip (N/O))
RESET, COM+	Reset input	DI-B, COM+	Programmable input B (default = Input trip (N/O))
START, COM+	Start/stop input		USB port (for flash, no direct PC connection)

5.4.2 Motor Thermistor

Motor thermistors can be connected directly to the VLT® Soft Starter MCD 600. The soft starter trips when the resistance of the thermistor circuit exceeds approximately 3.6 kΩ or drops below 20 Ω.

The thermistors must be wired in series. The thermistor circuit should be run in shielded cable and must be electrically isolated from ground and all other power and control circuits.

N O T I C E

The thermistor input is disabled by default, but activates automatically when a thermistor is detected. If thermistors have previously been connected to the MCD 600 but are no longer required, use the Thermistor Reset function to disable the thermistor. Thermistor reset is accessed via *Set-up Tools*.

5.4.3 Start/Stop

The VLT® Soft StarterMCD 600 requires 2-wire control.

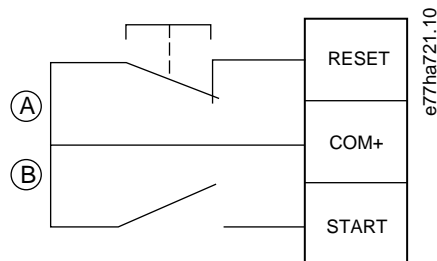

Illustration 8: Start/Stop Control Wiring

A	Reset
B	Start/stop

! C A U T I O N !

ATTEMPTED START

If the start input is closed when control voltage is applied, the soft starter attempts to start.

- Check that the start/stop input is open before applying control voltage.

N O T I C E

The MCD 600 only accepts command from the control inputs if *parameter 1-1 Command Source* is set to *Digital Input*.

5.4.4 Reset/Starter Disable

The reset input (RESET, COM+) is normally closed by default. The soft starter does not start if the reset input is open. The display then shows *Not ready*.

If the reset opens while the soft starter is running, the soft starter removes power and allows the motor to coast to stop.

N O T I C E

The reset input can be configured for normally open or normally closed operation. Make the selection in *parameter 7-9 Reset/Enable Logic*.

5.4.5 Programmable Inputs

The programmable inputs (DI-A, COM+ and DI-V, COM+) allow external equipment to control the soft starter. The operation of the programmable inputs is controlled by *parameters 7-1 to 7-8*.

5.4.6 USB Port

The USB port can be used to upload a configuration file or download parameter settings and event log information from the soft starter. See [6.7 USB Save & Load](#) for details.

5.5 Outputs

5.5.1 Output Terminals

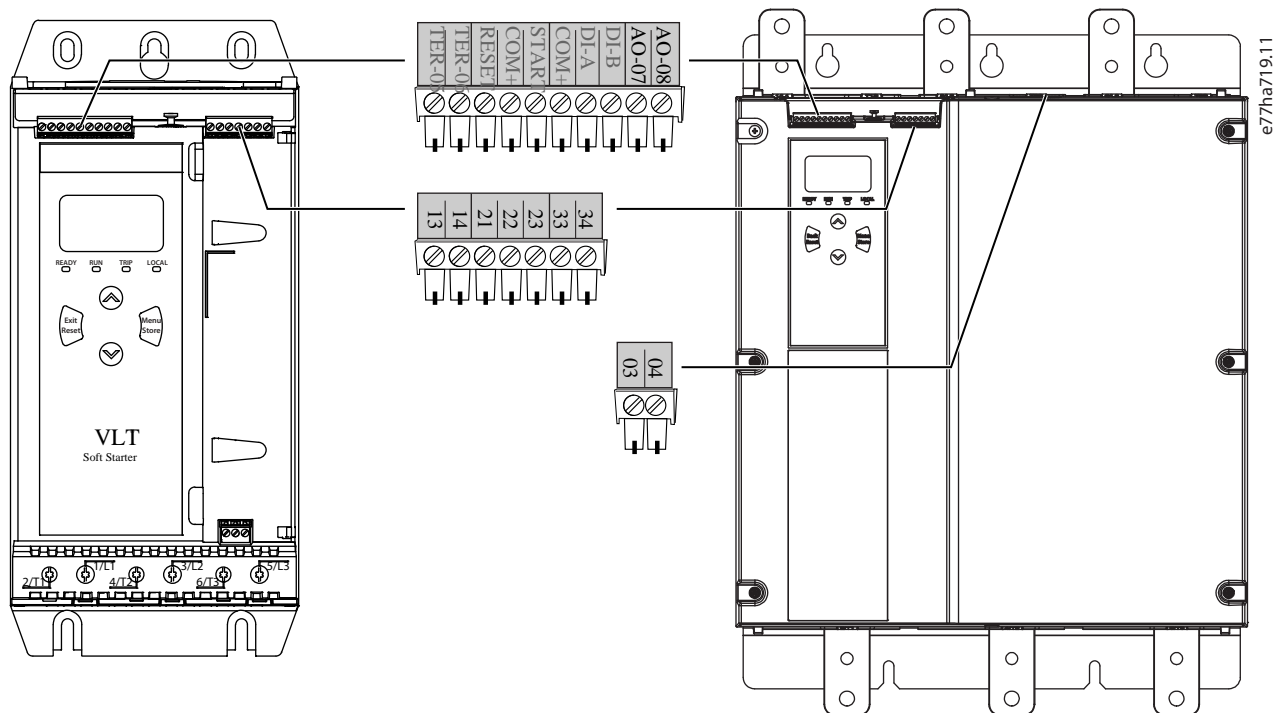

Illustration 9: Output Terminals

AO-07, AO-08	Analog output	33, 34	Relay output B (default = Run)
13, 14	Main contactor output	03, 04	Bypass contactor output
21, 22, 23	Relay output A (default = Run)		

5.5.2 Analog Output

The VLT® Soft Starter MCD 600 has an analog output, which can be connected to associated equipment to monitor motor performance. The operation of the analog output is controlled by *parameters 9-1 to 9-4*.

5.5.3 Main Contactor Output

The main contactor output (13, 14) closes when the soft starter receives a start command and remains closed while the soft starter is controlling the motor (until the motor starts a coast to stop, or until the end of a soft stop). The main contactor output also opens if the soft starter trips.

NOTICE

Use *parameter 20-8 Shunt Trip Mode* to configure the soft starter for use with a main contactor or circuit breaker.

- For use with a main contactor, use the default setting of *Disable*.
- For use with a circuit breaker, set *parameter 2-8 Shunt Trip Mode* to *Enable*.

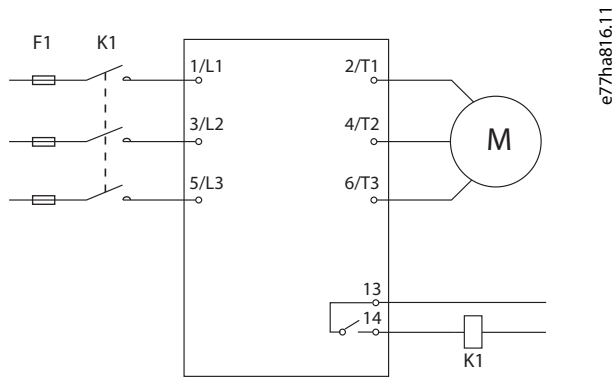

Illustration 10: Soft Starter Installed with Main Contactor

F1	Fuses
K1	Main contactor

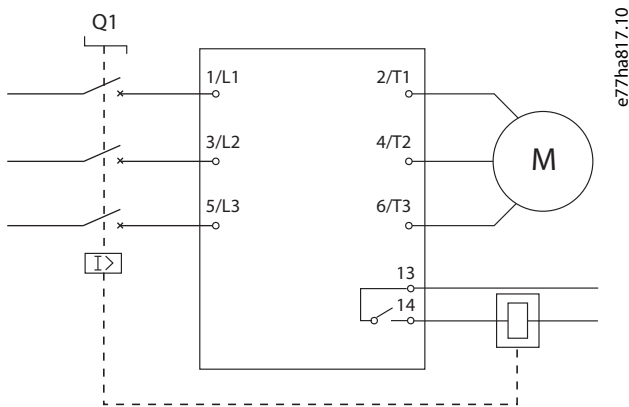

Illustration 11: Soft Starter Installed with a Shunt Relay and Circuit Breaker

Q1	Circuit breaker
----	-----------------

NOTICE

Some electronic contactor coils are not suitable for direct switching with PCB mount relays. Consult the contactor manufacturer/supplier to confirm suitability.

5.5.4 Bypass Contactor Output

The bypass contactor output (03, 04) closes when the soft start is complete (when the starting current drops below 120% of the programmed motor full load current) and remains closed until the beginning of a stop (either soft stop or coast to stop).

NOTICE

This output is only available on models MCD6-0590C~MCD6-1134C.

NOTICE

If a non-bypassed soft starter is installed with an external bypass contactor, the soft starter current rating changes. Enable *parameter 20-7 External Bypass* to increase the maximum current rating and adjust the soft starter thermal model.

5.5.5 Programmable Outputs

The programmable outputs (21, 22, 23 and 33, 34) can report the status of the soft starter or can control associated equipment. The operation of the programmable outputs is controlled by *parameters 8-1 to 8-6*.

5.6 Control Voltage

5.6.1 Control Voltage Terminals

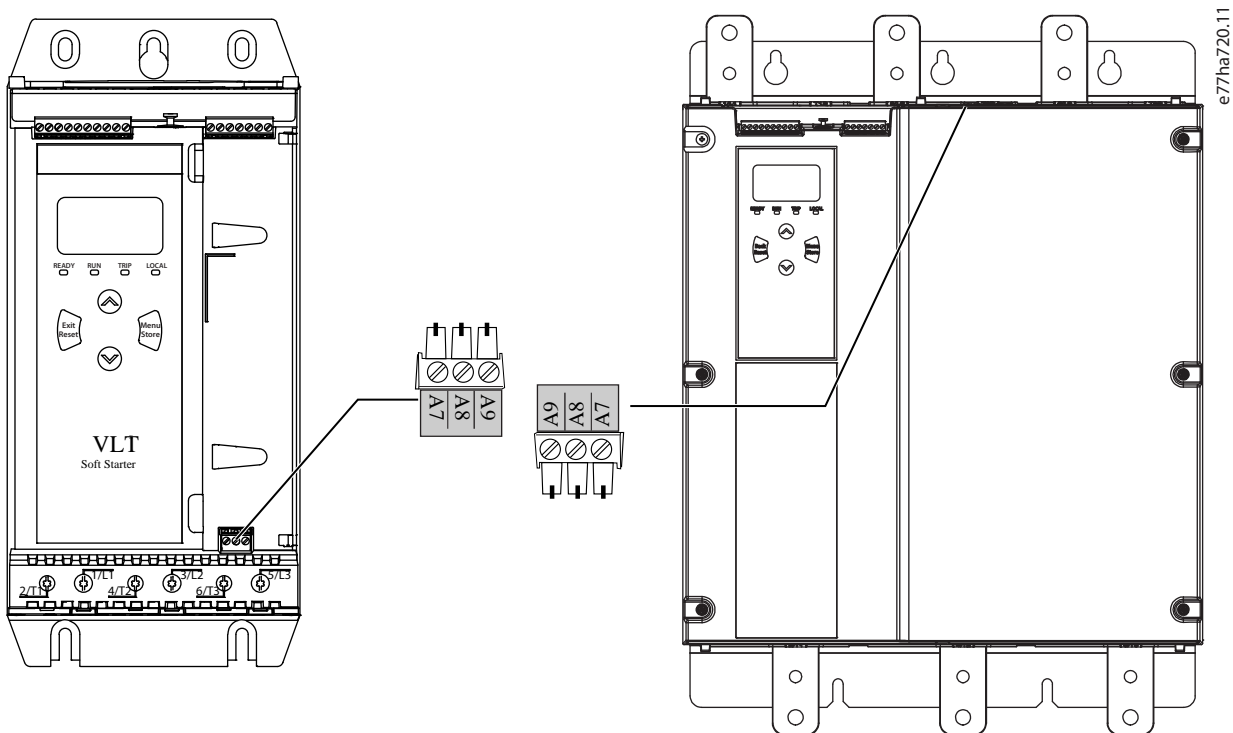

Illustration 12: Control Voltage Terminals

Connect the control supply according to the supply voltage being used.

- MCD6-xxxxB-xx-CV2 (110–120 V AC): A8, A9.
- MCD6-xxxxB-xx-CV2 (220–240 V AC): A7, A9.
- MCD6-xxxxB-xx-CV1 (24 V AC/V DC): A8, A9.

Install supplementary or branch circuit overcurrent protection on the control circuit supply (A7, A8, A9) in accordance with the electrical code applicable at the installation location.

5.7 Power Terminations

⚠ WARNING ⚠

SHOCK HAZARD

Models MCD6-0144B to MCD6-1250B and MCD6 0590C to MCD6-1134C are IP00 and pose a risk of electrical shock if touching the terminals.

- Install a finger guard kit on the soft starter.
- Install the soft starters inside an enclosure, or
- install a cover, for example a plexiglass cover, to prevent touching the terminals.

On frame sizes S1 and S2, the power input and output terminals for VLT® Soft StarterMCD 600 are at the bottom of the unit. On frame size S3, the power input is at the top and the power output is at the bottom.

e77ha822.10

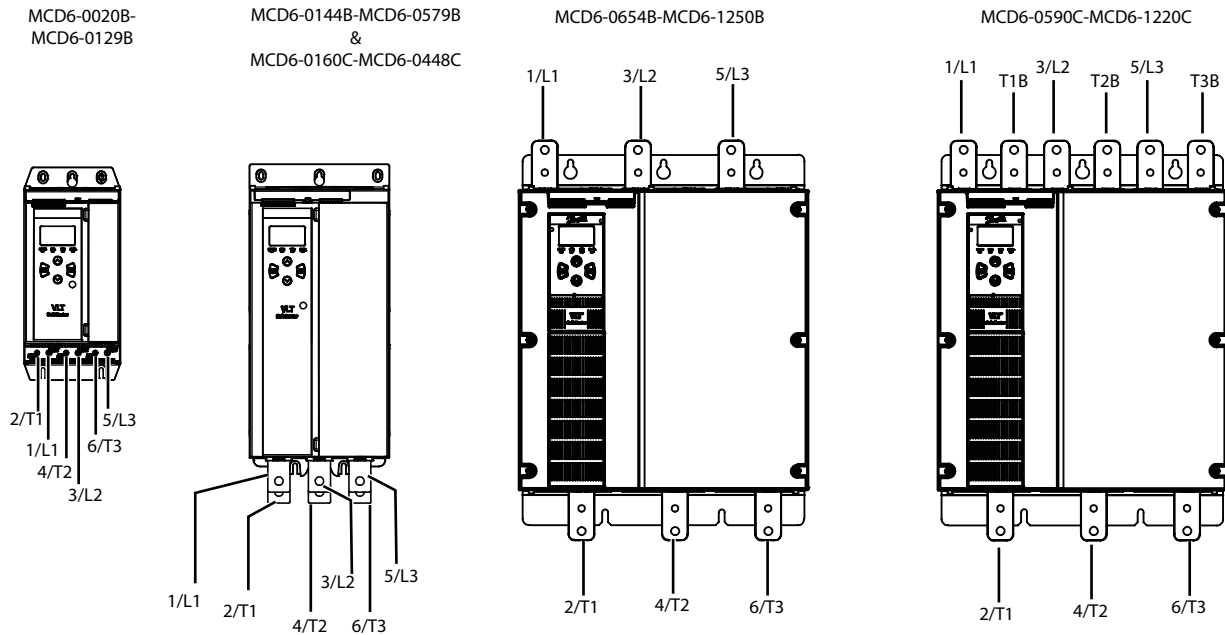

Illustration 13: Input and Output Terminals for Power Terminations

- Models MCD6-0020B~MCD6-0129B use cage clamps. Use copper stranded or solid conductors rated for 75 °C (167 °F) or higher.
- Models MCD6-0144B~MCD6-1250B and MCD6-0160C~MCD6-1134C use busbars. Use copper or aluminum conductors, stranded or solid, rated for 60/75 °C (140/167 °F).
- Models MCD6-0654B~MCD6-1250B/MCD6-0160C~MCD6-1134C use busbars. Input terminals are at the top of the unit and output terminals are at the bottom.
- Models MCD6-0590C~MCD6-1134C have dedicated bypass terminals, if the soft starter will be installed with an external bypass contactor. The bypass busbars are at the top of the unit and are labeled T1B, T2B, T3B.

NOTICE

When connecting power terminations, clean the surface contact area thoroughly (using an emery or stainless steel brush) and use an appropriate jointing compound to prevent corrosion.

Table 21: Power Terminations, MCD6-0020B~MCD6-0129B

MCD6-0020B~MCD6-0129B			
 e77ha646.11	Cable size: 6–70 mm ² (AWG 10–2/0) Torque: 4 Nm (2.9 ft-lb)	 e77ha648.11	Torx T20 x 150
 e77ha647.11	14 mm (0.55 in)	 e77ha649.11	Flat 7 mm x 150

Table 22: Power Terminations, MCD6-0144B~MCD6-0244B, MCD6-0287B~MCD6-0579B, and MCD6-0160C~MCD6-0448C

MCD6-0144B~MCD6-0244B	MCD6-0287B~MCD6-0579B and MCD6-0160C~MCD6-0448C
19 Nm (14 ft-lb)	66 Nm (49 ft-lb)

Table 23: Power Terminations, 0654B~1250B & 0590C~1134C

0654B~1250B & 0590C~1134C	
	66 Nm (49 ft-lb)

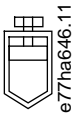
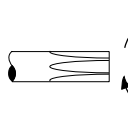
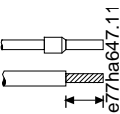
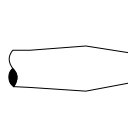
NOTICE

If the installation requires large diameter cables, it is possible to complete each termination with 2 smaller cables, 1 on each side of the busbar.

5.7.1 Wiring Connectors

Select a connector according to the wire size, material, and application requirements.

5.7.1.1 Models MCD6-0144B~MCD6-0579B

For models MCD6-0144B to MCD6-0579B, a compression connector is recommended. The recommended crimping tool is TBM8-750.

NOTICE

S3 internal bypass model has 6 busbars (x3 for AC in, x3 for motor out), meaning that 2 x 157G0203 are required. S3 external bypass models have 9 busbars (x3 for AC in, x3 for bypass, x3 for motor out) meaning that 3 x 157G0203 are required.

Table 24: Recommended Lugs

Model	Example connector - aluminum cable	Example connector - copper cable
MCD6-0144B	61162	60150
MCD6-0171B	61165	60156
MCD6-0194B	61171	60165
MCD6-0244B		
MCD6-0287B	61162	60150

5.7.1.2 Models MCD6-0654B~MCD6-1250B & MCD6-0590C~MCD6-1134C

For models MCD6-0144B to MCD6-0579B, a compression connector is recommended. The recommended crimping tool is TBM8-750.

NOTICE

A terminal lug is recommended for models MCD6-0654B~MCD6-1250B and MCD6-0590C~MCD6-1134C. The recommended lug is TCAL125. To use a lug, these models require busbar link 175G0203.

- MCD6-0654B~MCD6-1250B have 6 busbars (x3 for AC in, x3 for motor out) and require 2 x 157G0203.
- MCD6-0590C~MCD6-1134C have 9 busbars (x3 for AC in, x3 for bypass, x3 for motor out) and require 3 x 157G0203.

Table 25: Recommended Lugs

Model	Example connector - aluminum cable	Example connector - copper cable
MCD6-0352B	61165	60156
MCD6-0410B		60156
MCD6-0527B	61178	60171
MCD6-0579B		

5.8 External Bypass Contactor

Models MCD6-0590C~MCD6-1134C have dedicated bypass terminals, which allow the protection and monitoring functions of the soft starter to work even when the soft starter is externally bypassed.

Use the bypass contactor output (03, 04) to control the external bypass.

⚠ WARNING ⚠

SHOCK HAZARD

When the soft starter is wired in inside delta configuration, it results in a portion of the motor windings being connected to line power at all times (even when the soft starter is switched off). This situation may cause death or serious personal injury.

- Always install a main contactor or shunt trip circuit breaker when connecting the soft starter in inside delta configuration.

NOTICE

Models MCD6-0160C~MCD6-0448C are not suitable for installation with an external bypass contactor.

NOTICE

If a non-bypassed soft starter is installed with an external bypass contactor, the soft starter's current rating changes. Enable *parameter 20-7 External Bypass* to increase the maximum current rating and adjust the soft starter's thermal model.

5.9 Motor Connection

The VLT® Soft Starter MCD 600 can be connected to the motor in-line or inside delta (also called 3-wire and 6-wire connection).

When connecting in inside delta, enter the FLC for *parameter 1-2 Motor Full Load Current*. The MCD 600 automatically detects whether the motor is connected in-line or inside delta and calculates the correct inside delta current level.

NOTICE

If the soft starter is not detecting the motor connection correctly, use *parameter 20-6 Motor Connection*.

5.9.1 In-line Installation, Internally Bypassed

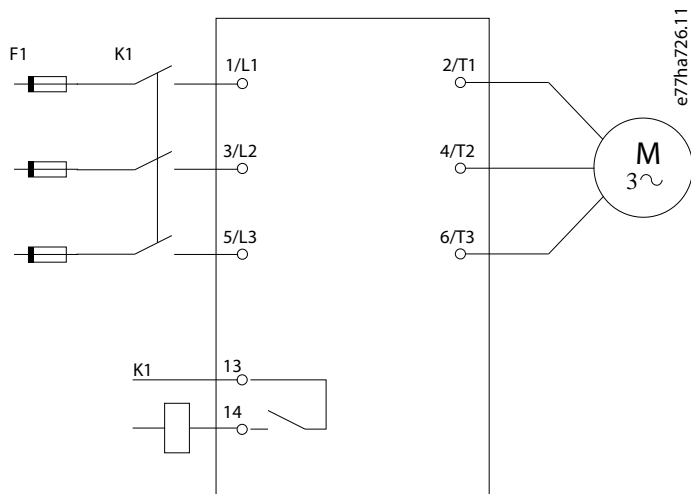

Illustration 14: Wiring of an In-line Installation

K1	Main contactor (strongly recommended)	13, 14	Main contactor output
F1	Fuses or circuit breaker		

5.9.2 In-line Installation, Externally Bypassed

Models MCD6-0590C~MCD6-1134C have dedicated bypass terminals, which allow the protection and monitoring functions of the soft starter to work even when the soft starter is externally bypassed.

The bypass busbars are at the top of the unit and are labeled T1B, T2B, T3B.

The bypass contactor must be connected to the bypass terminals and controlled by the soft starter's bypass contactor output (terminals 03, 04).

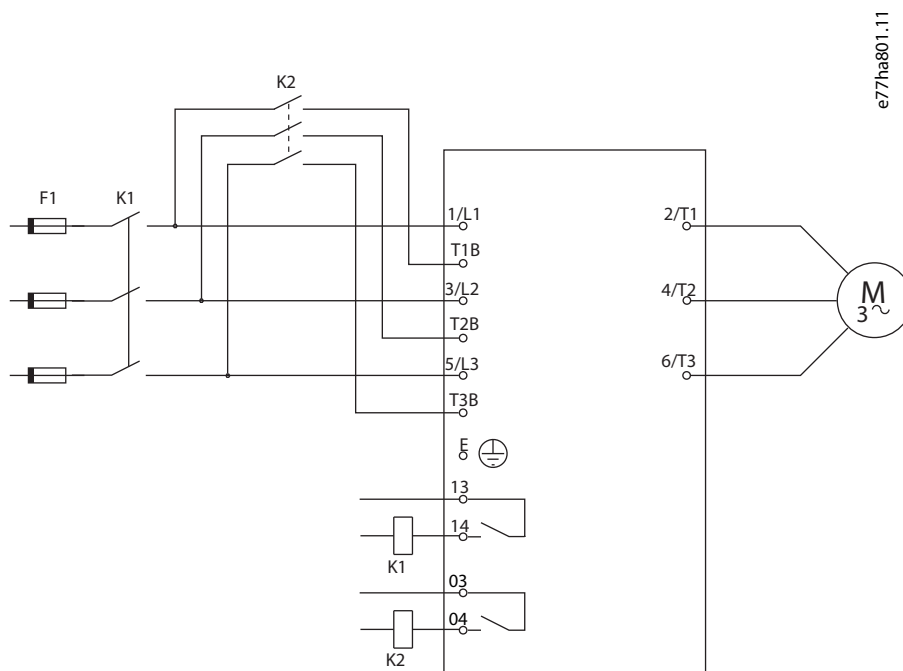

K1	Main contactor (strongly recommended)	13, 14	Main contactor output
K2	Bypass contactor	03, 04	Bypass contactor output
F1	Fuses or circuit breaker		

5.9.3 Inside Delta Installation, Internally Bypassed

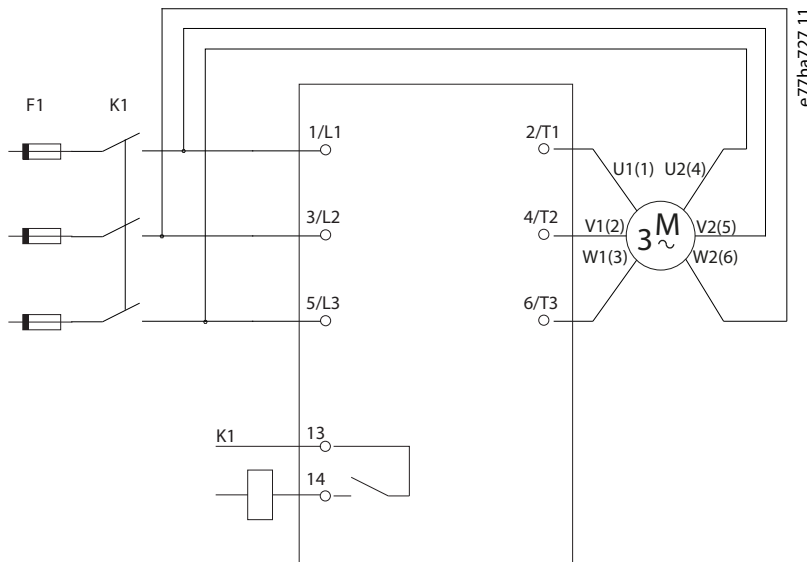

Illustration 15: Wiring of an Inside Delta Installation

K1	Main contactor	13, 14	Main contactor output
F1	Fuses or circuit breaker		

5.9.4 Inside Delta Installation, Externally Bypassed

Models MCD6-0590C~MCD6-1134C have dedicated bypass terminals, which allow the protection and monitoring functions of the soft starter to work even when the soft starter is externally bypassed.

The bypass busbars are at the top of the unit and are labeled T1B, T2B, T3B.

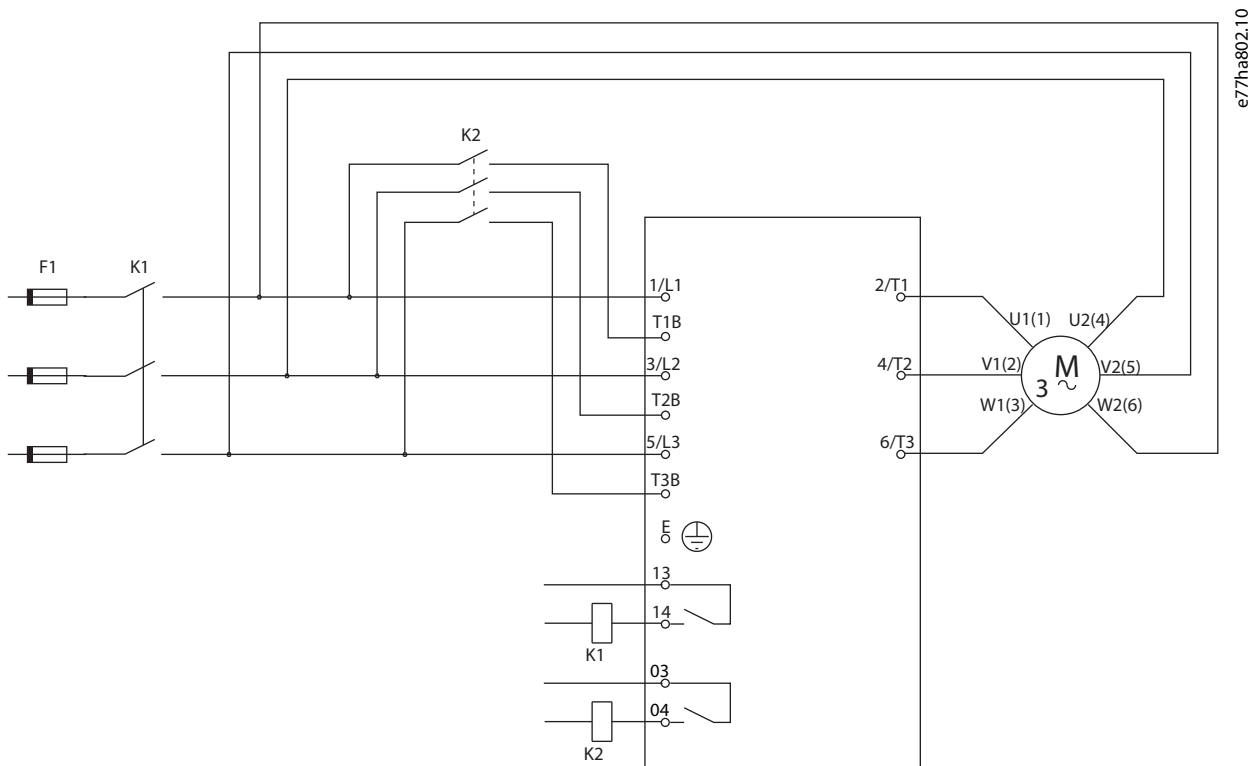

Illustration 16: Wiring of Inside Delta Installation, Externally Bypassed

K1	Main contactor	13, 14	Main contactor output
K2	Bypass contactor (external)	03, 04	Bypass contactor output
F1	Fuses or circuit breaker		

5.9.5 Ground Terminations

Models MCD6-0654B~MCD6-1250B/MCD6-0590C~MCD6-1134C have a ground terminal on each side of the soft starter, near the top back corner. Either grounding point may be used.

Models MCD6-0020B~MCD6-0579B/MCD6-0160C~MCD6-0448C do not require a protective earth connection. All internal conductive parts are fully enclosed by a non-conductive outer case.

5.10 Typical Installations

5.10.1 Internally Bypassed Installation

The VLT® Soft Starter MCD 600 is installed with a main contactor (AC3-rated). Control voltage must be supplied from the input side of the contactor.

The main contactor is controlled by the main contactor output (13, 14).

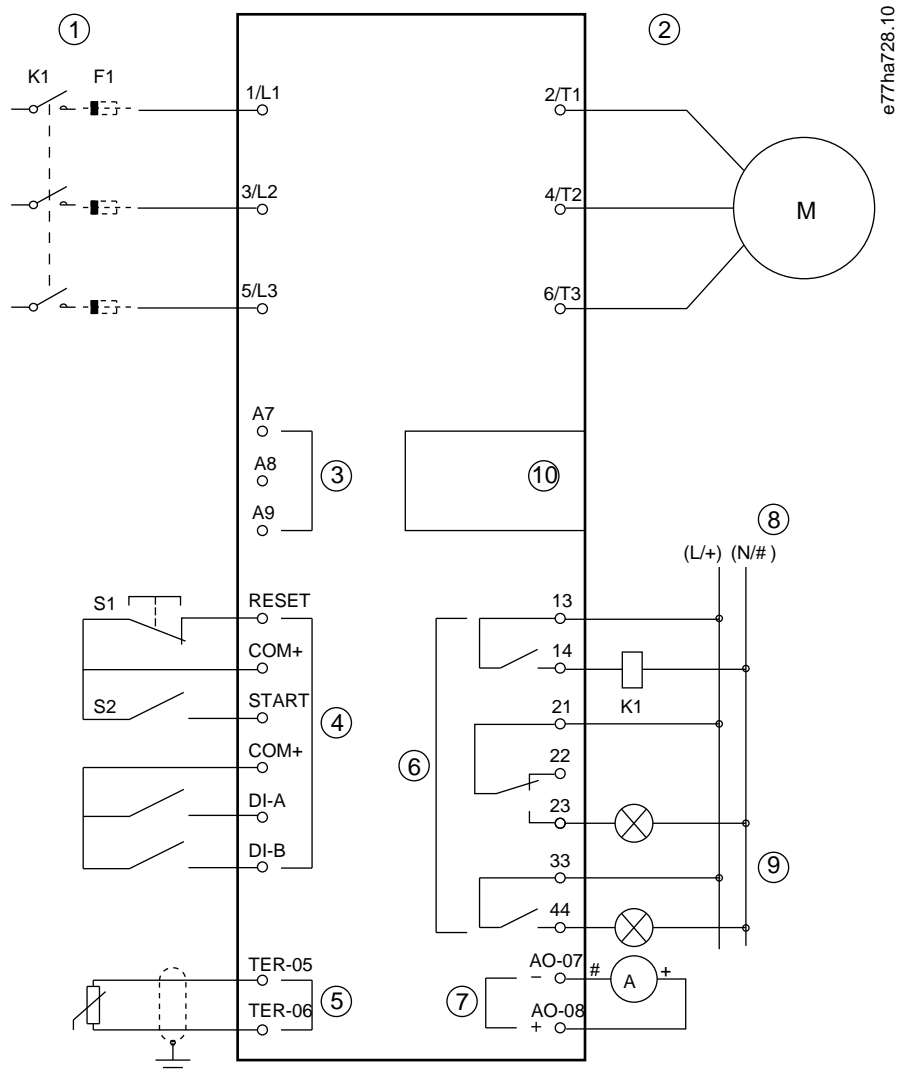

Illustration 17: Example of Internally Bypassed Installation

1	Three-phase supply	F1	Fuses or circuit breaker
2	Motor	RESET, COM+ (S1)	Reset
3	Control voltage (soft starter)	START, COM+ (S2)	Start/stop
4	Digital inputs	DI-A, COM+	Programmable input A (default = Input trip (N/O))
5	Motor thermistor input	DI-B, COM+	Programmable input B (default = Input trip (N/O))
6	Relay outputs	TER-05, TER-06	Motor thermistor input
7	Analog output	13, 14	Main contactor output
8	Control voltage (external equipment)	21, 22, 23	Relay output A (default = Run)
9	Pilot lamps	33, 34	Relay output B (default = Run)
10	Communications/smart card expansion port	AO-07, AO-08	Analog output
K1	Main contactor		

5.10.2 Externally Bypassed Installation

The soft starter is installed with a main contactor (AC3-rated) and an external bypass contactor. To bypass the soft starter during run, use an external bypass contactor with an AC1 rating. To bypass the soft starter completely (to allow direct on-line starting if the soft starter is damaged), use an external bypass contactor with an AC3 rating.

Use the main contactor output (13, 14) to control the main contactor. Use the bypass contactor output (03, 04) to control the external bypass.

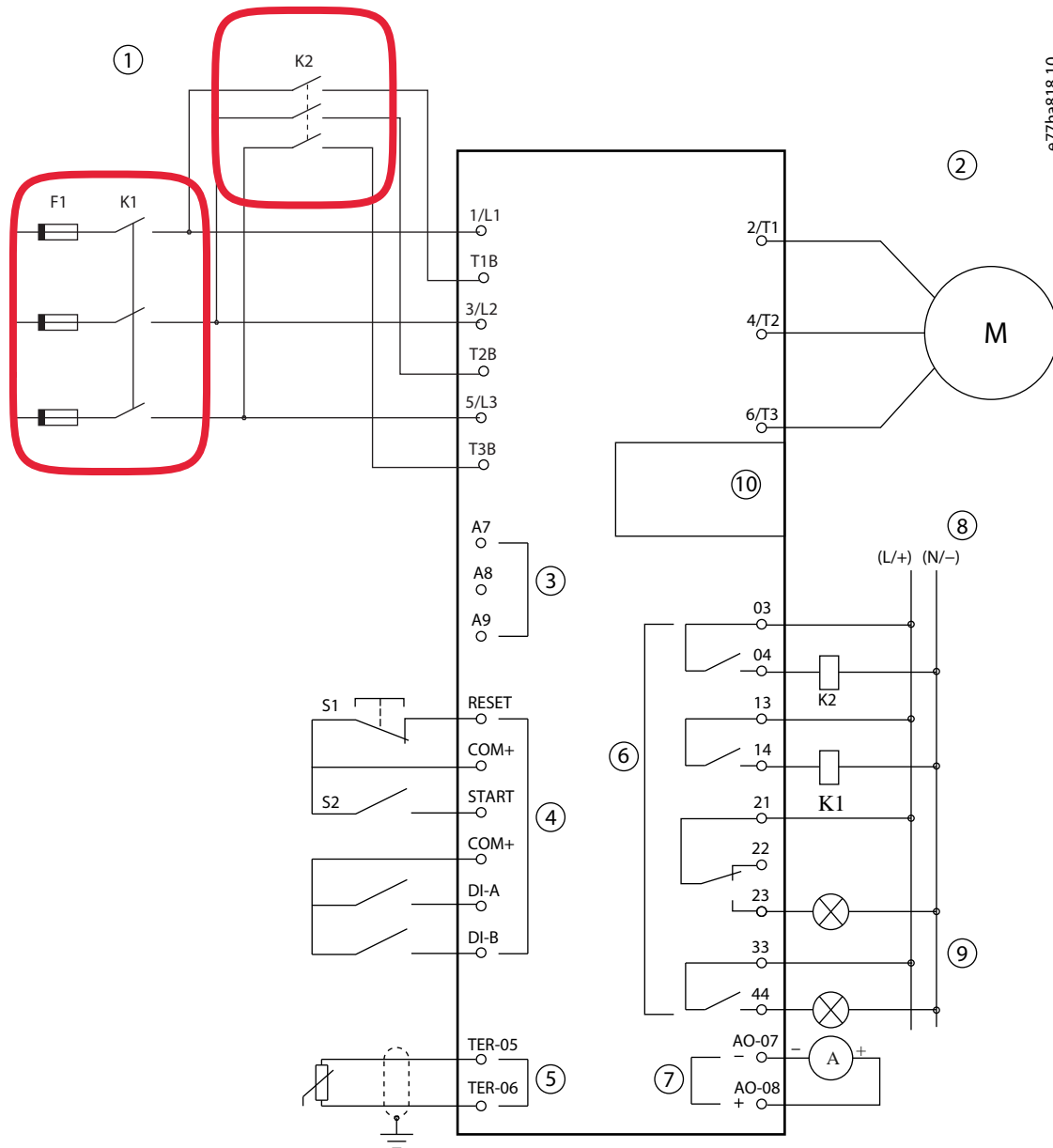

e77ha818.10

Illustration 18: Example of Externally Bypassed Installation

1	Three-phase supply	F1	Fuses or circuit breaker
2	Motor	RESET, COM+ (S1)	Reset
3	Control voltage (soft starter)	START, COM+ (S2)	Start/stop
4	Digital inputs	DI-A, COM+	Programmable input A (default = Input trip (N/O))
5	Motor thermistor input	DI-B, COM+	Programmable input B (default = Input trip (N/O))
6	Relay outputs	TER-05, TER-06	Motor thermistor input
7	Analog output	13, 14	Main contactor output
8	Control voltage (external equipment)	21, 22, 23	Relay output A (default = Run)
9	Pilot lamps	33, 34	Relay output B (default = Run)
10	Communications/Smart card expansion port	03, 04	Bypass contactor output
K1	Main contactor	AO-07, AO-08	Analog output
K2	Bypass contactor (external)		

5.11 Quick Set-up

The Quick Set-up makes it easy to configure the soft starter for common applications. The VLT® Soft Starter MCD 600 guides the user through the most common installation parameters and suggests a typical setting for the application. Adjust each parameter to suit the exact requirements.

All other parameters remain at default values. To change other parameter values or review default settings, use the Main Menu (see [10.4 Parameter List](#) for details).

Always set *parameter 1-2 Motor Full Load Current* to match the motor nameplate FLC.

Table 26: Suggested Settings for Common Applications

Application	Start mode	Start ramp time [s]	Initial current [%]	Current limit [%]	Adaptive start profile	Stop mode	Stop time [s]	Adaptive stop profile
Pump centrifugal	Adaptive control	10	200	500	Early acceleration	Adaptive control	15	Late deceleration
Pump bore	Adaptive control	3	200	500	Early acceleration	Adaptive control	3	Late deceleration
Pump hydraulic	Constant current	2	200	350	n/a	Coast to stop	n/a	n/a
Fan damped	Constant current	2	200	350	n/a	Coast to stop	n/a	n/a
Fan undamped	Constant current	2	200	450	n/a	Coast to stop	n/a	n/a
Compressor screw	Constant current	2	200	400	n/a	Coast to stop	n/a	n/a

Application	Start mode	Start ramp time [s]	Initial current [%]	Current limit [%]	Adaptive start profile	Stop mode	Stop time [s]	Adaptive stop profile
Compressor reciprocating	Constant current	2	200	450	n/a	Coast to stop	n/a	n/a
Conveyor	Constant current	5	200	450	n/a	Coast to stop	n/a	n/a
Bow thruster	Constant current	5	100	400	n/a	Coast to stop	n/a	n/a
Bandsaw	Constant current	2	200	450	n/a	Coast to stop	n/a	n/a

N O T I C E

The adaptive start and stop profile settings only apply when using adaptive control. The settings are ignored for all other start and stop modes.

6 Set-up Tools

6.1 Introduction

Set-up Tools includes options to load or save parameters to a backup file, set the soft starter's network address, check the status of the inputs and outputs, reset the thermal models, or test operation using the *Run Simulation*.

To access *Set-up Tools*, press [Menu/Store] to open the Main Menu and then select *Set-up Tools*.

6.2 Setting Date and Time

Procedure

1. Press [Menu/Store] to open the menu.
2. Select *Set-up Tools*.
3. Scroll to *Set Date & Time*.
4. Press [Menu/Store] to enter edit mode.
5. Press [Menu/Store] and [Back] to select which part of the date or time to edit.
6. Press [▲] and [▼] to change the values.
7. Press [Menu/Store] after the last digit to save the setting.

When the action has been completed, the screen briefly shows a confirmation message, then returns to the previous menu level.

6.3 Command Source

Start and stop the soft starter via the digital inputs, remote LCP 601, communication network, smart card, or scheduled auto-start/stop. Set up the command source via *Set-up Tools* or via *parameter 1-1 Command Source*.

If the remote LCP is installed, the [CMD/Menu] key provides shortcut access to the Command Source function in *Setup Tools*.

6.4 Commissioning

Commissioning allows starting and stopping the soft starter via the LCP. Press [▲] [▼] to select a function, then press [Menu/Store] to send the selected command to the soft starter. The available functions are:

- Quick stop (coast to stop)/reset.
- Start.
- Stop.

6.5 Run Simulation

The Run Simulation simulates a motor starting, running, and stopping to confirm that the soft starter and associated equipment have been installed correctly.

N O T I C E

Disconnect the soft starter from mains voltage when using simulation mode.

The simulation is only available when the soft starter is in ready state.

Procedure

1. Press [Menu/Store] and select *Setup Tools*.
2. Scroll to *Run Simulation* and press [Menu/Store].

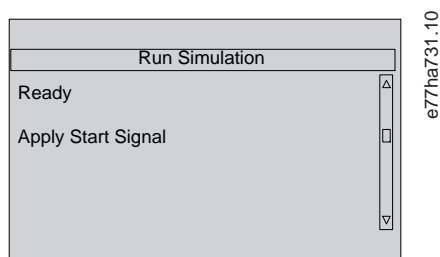

3. Apply a start command from the selected command source.

→ The soft starter simulates its prestart checks and closes the main contactor relay. The Run LED flashes.

NOTICE

If mains voltage is connected, an error message is shown.

4. Press [Menu/Store].

→ The soft starter simulates starting.

5. Press Menu/Store.

→ The soft starter simulates running.

6. Apply a stop command from the selected command source.

→ The soft starter simulates stopping. The Run LED flashes.

7. Press [Menu/Store].

→ The Ready LED flashes and the main contactor relay opens.

8. Press [Menu/Store].

→ The soft starter activates then deactivates each programmable output.

9. Press [Menu/Store].

→ The soft starter returns to the *Setup Tools*.

6.6 Load/Save Settings

The *Load/Save Settings* allows:

- Resetting the soft starter parameters to default values.
- Loading parameter settings from an internal file.
- Saving the current parameter settings to an internal file.

The internal file contains default values until a user file is saved.

Procedure

1. Press [Menu/Store] and select *Setup Tools*.
2. Scroll to *Load/Save Settings* and press [Menu/Store].

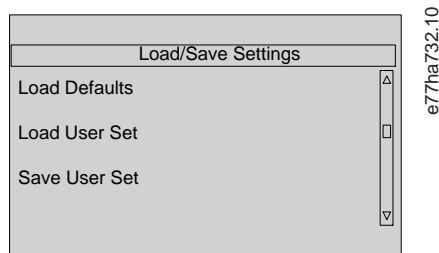

3. Scroll to the required function and press [Menu/Store].
4. At the confirmation prompt, select *Yes* to confirm or *No* to cancel.
5. Press [Menu/Store] to proceed.

When the action has been completed, the screen briefly shows a confirmation message, then returns to the previous menu level.

6.7 USB Save & Load

The *USB Save & Load* menu allows:

- Saving parameter settings and all event log entries to an external file (CSV format).
- Saving parameter settings to an external file (proprietary format).
- Loading parameter settings from a previously saved external file.
- Loading custom messages to show on the LCP when a programmable input is active.

N O T I C E

The VLT® Soft Starter MCD 600 supports FAT32 file systems. The MCD 600 USB functions are not compatible with NTFS file systems.

6.7.1 Save and Load Procedure

Procedure

1. Connect the external drive to the USB port.
2. Press [Menu/Store] and select *Setup Tools*.
3. Scroll to *USB Save & Load* and press [Menu/Store].

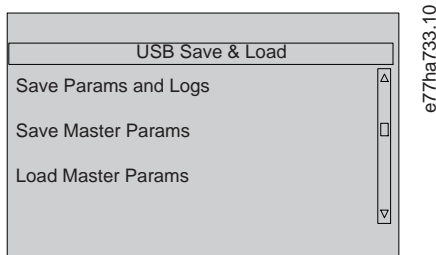

4. Scroll to the required function and press [Menu/Store].
5. At the confirmation prompt, select *Yes* to confirm or *No* to cancel.
6. Press [Menu/Store] to proceed.

When the action has been completed, the screen briefly shows a confirmation message, then returns to the previous menu level.

6.7.2 File Locations and Formats

Save parameters and logs

The soft starter creates a directory at the top level of the USB drive, named with the soft starter serial number. The event log and parameter settings are saved as individual CSV files, and the soft starter's software and system information are saved to a text file.

Save master parameters

The soft starter creates a file called *Master_Parameters.par* in the top level of the USB drive.

Load master parameters

The soft starter loads the file *Master_Parameters.par* from the top level of the USB drive. The file can be created or edited using VLT® Motion Control Tool MCT 10. Download the MCT 10 tool from www.danfoss.com under the sections *Service and support/Downloads*.

Load custom message

The soft starter loads the files *Custom_Message_A.txt* and *Custom_Message_B.txt* from the top level of the USB drive.

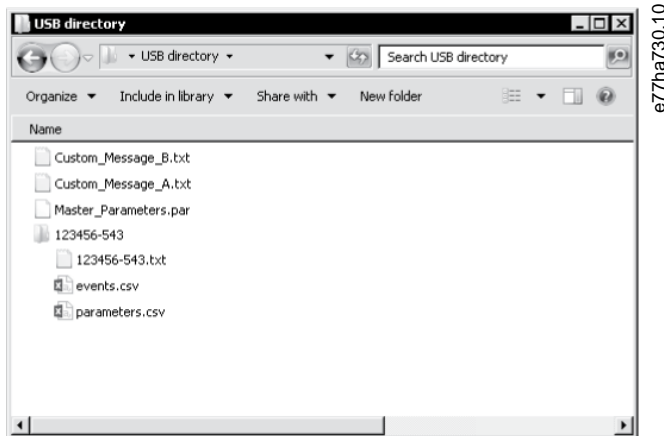

Illustration 19: USB Directory

6.8 Auto-start/Stop

The soft starter can be configured to automatically start and/or stop the motor at a particular time, or run it in cycles of a specified duration.

The *Auto-Start/Stop* function in *Set-up Tools* gives quick access to the auto-start/stop parameters.

Procedure

1. Press [Menu/Store] and select *Setup Tools*.
2. Scroll to *Auto-Start/Stop* and press [Menu/Store].

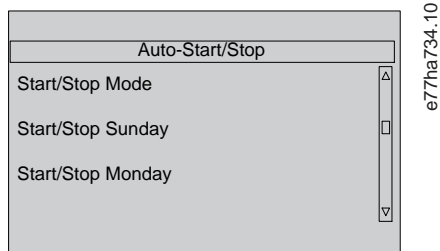

3. Scroll to the required function and press [Menu/Store].
4. Adjust the settings as required:
 - a. Press [Menu/Store] and [Back] to select which information to edit.
 - b. Press [▲] [▼] to change the value.
 - Press [Menu/Store] to save the changes. The soft starter confirms the changes.
 - Press [Back] to cancel the changes.

6.9 Network Address

To use the VLT® Soft Starter MCD 600 on an Ethernet network, separate addresses must be configured for:

- IP address.
- Gateway address.
- Subnet mask.

6.9.1 Setting a Network Address

Procedure

1. Press [Menu/Store] and select *Setup Tools*.
2. Scroll to *Network Address* and press [Menu/Store].
3. Scroll to the required function and press [Menu/Store].

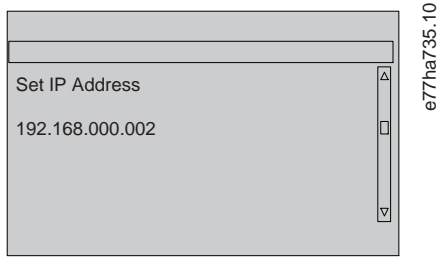

4. The 1st digit of the address is highlighted.
5. Press [Back] and [Menu/Store] to select which digit to alter.
6. Press [▲] [▼] to change the value.
7. Press [Menu/Store] after the last digit to save the setting.

When the action has completed, the screen briefly shows a confirmation message, then returns to the previous menu level.

NOTICE

The network address can also be set by using *parameters 12-8 to 12-19*.

NOTICE

To configure the soft starter for use with other communication protocols, use *parameters 12-1 to 12-7*.

6.10 Digital I/O State

The top line of the screen shows the start/stop, reset, and programmable inputs. The bottom line of the screen shows the fixed main contactor output, then programmable outputs A and B.

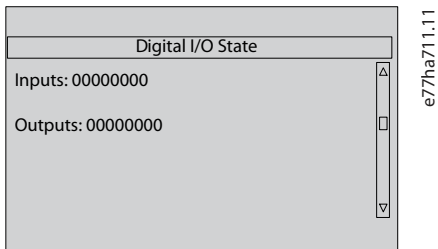

Illustration 20: Digital I/O Status Screen

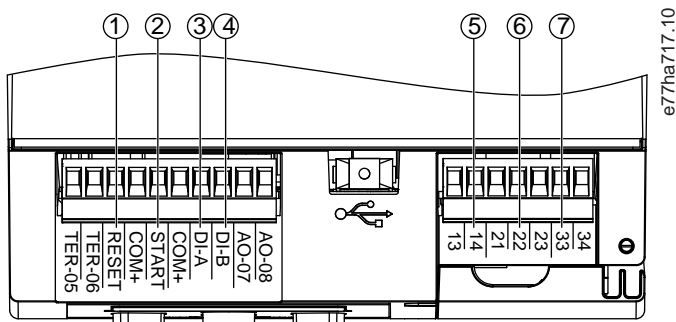

Illustration 21: Location of Digital I/Os

1	RESET, COM+: Reset input	5	13, 14: Main contactor output
2	START, COM+: Start/stop input	6	21, 22, 23: Relay output A
3	DI-A, COM+: Programmable input A	7	33, 34: Relay output B
4	DI-B, COM+: Programmable input B		

6.11 Analog I/O State

The topline of the screen shows the state of the motor thermistor input. The bottom line of the screen shows the value of the analog output.

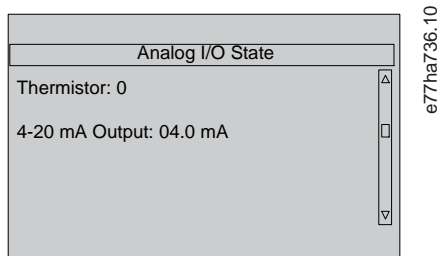

Illustration 22: Analog I/O Status Screen

Thermistor input

S	Short
H	Hot
C	Cold
O	Open

6.12 Serial Number & Rating

The top line of the screen shows the product name.

The middle line shows the unit's serial number.

The bottom line of the screen shows the model number.

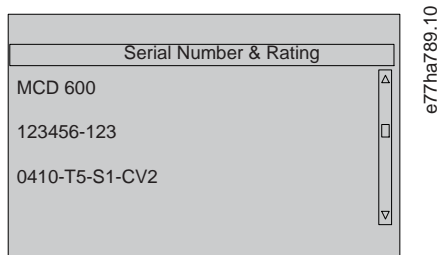

Illustration 23: Serial Number & Rating Screen

6.13 Software Versions

The software version screen reports the version of each software component of the soft starter:

- User interface.
- Motor control.
- Remote LCP (if connected).
- Parameter list.
- Bootloader.
- Expansion card (if fitted).

NOTICE

Updated software, including alternative languages, can be loaded into the soft starter via the USB port if required. Contact the local supplier for further information.

6.14 Thermistor Reset

The thermistor input is disabled by default, but activates automatically when a thermistor is detected. If thermistors have previously been connected to the soft starter but are no longer required, use the thermistor reset function to disable the thermistor.

6.15 Reset Thermal Model

The thermal modeling software in the soft starter constantly monitors the motor performance. This allows the soft starter to calculate the motor temperature and ability to start successfully at any time.

The thermal model can be reset if required.

NOTICE

REDUCED MOTOR LIFETIME

Resetting the motor thermal model compromises thermal model protection and may compromise motor life.

- Only reset the thermal model in an emergency.

7 Logs

7.1 Introduction

The Logs Menu provides information on events, trips, and soft starter performance.

To access the Logs Menu on the local LCP, press [Menu/Store] and select *Logs*. On the remote LCP, press [Logs].

7.2 Event Log

The Event Log stores details of the most recent trips, warnings, and operations (including starts, stops, and configuration changes).

Event 1 is the most recent and event 384 is the oldest stored event.

NOTICE

The Event Log can be exported to an external file for analysis away from the soft starter.

See [6.7.2 File Locations and Formats](#).

7.3 Counters

The counters store statistics on the soft starter operation:

- Hours run (lifetime and since counter was last reset).
- Number of starts (lifetime and since counter was last reset).
- Number of times the thermal model has been reset.

7.3.1 Viewing the Counters

Procedure

1. Open the *Logs*, see [7.1 Introduction](#).
2. Scroll to *Counters* and press [Menu/Store].
3. Press [▲] and [▼] to scroll through the counters.
4. Press [Menu/Store] to view details.
5. To reset a counter, press [Menu/Store] then press [▲] and [▼] to select *Reset/Do Not Reset*.
6. Press [Store] to confirm the action.
7. Press [Menu/Store] to close the counter and return to *Logs*.

7.4 QR Code

The soft starter can generate a QR code which allows a smartphone to show key information about the soft starter, including serial number, firmware versions, installed options, plus details of the 3 most recent trips of the soft starter. This information is helpful when requesting assistance from the local supplier.

NOTICE

To read the QR code, install the soft starter support app. Contact the local supplier for further information.

8 LCP and Feedback

8.1 Local LCP and Feedback

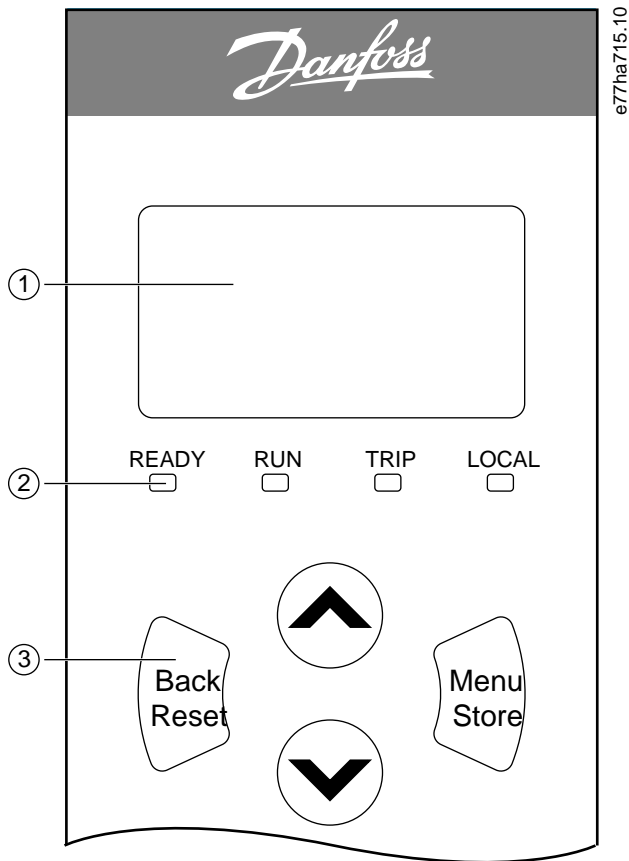

Illustration 24: Local LCP

1	Four-line display for status and programming details.	3	Menu navigation keys ⁽¹⁾
2	Status LEDs.		

- 1
- Back/Reset: Exit the menu or parameter, or cancel a parameter change. This key also resets a trip.
 - Menu/Store: Enter a menu or parameter, or save a parameter change.
 - Arrows: Scroll to the next or previous menu or parameter, change the setting of the current parameter, or scroll through the status screens.

8.2 Remote LCP

The remote LCP can be used to control the soft starter if *parameter 1-1 Command Source* is set to *Remote Keypad*.

- If the remote LCP is not selected as the command source, [Start], [Stop], and [Reset] have no effect.
- The menu navigation keys and display on the remote LCP are always active.
- If a key is pressed on the local LCP, the display on the remote LCP updates to match.

NOTICE

The remote LCP can be safely connected or removed while the soft starter is running. It is not necessary to remove mains or control voltage.

NOTICE

If parameter 1-1 Command Source is set to Remote Keypad, removing the remote LCP causes a trip.

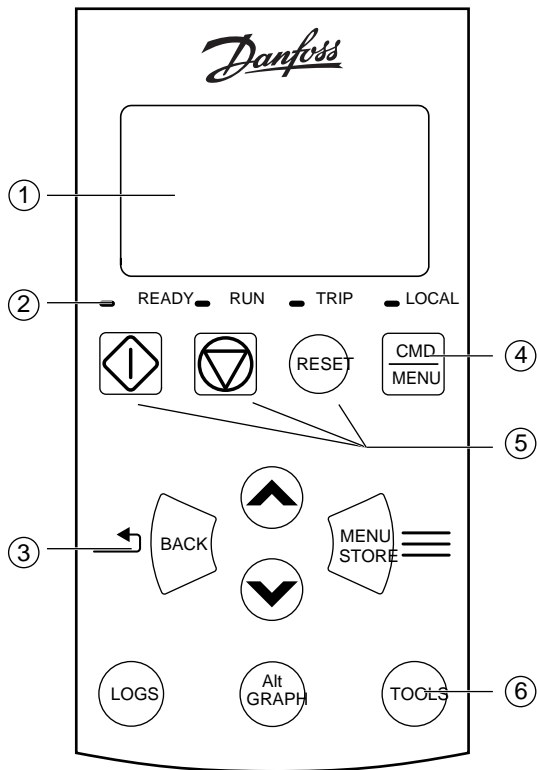

e77ha716.10

3. (4

Illustration 25: Remote LCP

1	Four-line display for status and programming details.	4	Shortcut to the command source menu in <i>Set-up Tools</i> .
2	Status LEDs.	5	Local control keys.
3	Menu navigation keys ⁽¹⁾	6	Shortcut keys for quick access to common tasks ⁽²⁾

1

- Back: Exit the menu or parameter, or cancel a parameter change.
- Menu/Store: Enter a menu or parameter, or save a parameter change.
- Arrow keys: Scroll to the next or previous menu or parameter, change the setting of the current parameter, or scroll through the status screens.

2

- Logs: Open the Logs Menu.
- Graph: Select which graph to view, or pause/restart the graph (hold longer than 0.5 s).
- Tools: Open the *Setup Tools*.

8.3 Adjusting the Display Contrast

NOTICE

The local and remote LCPs can be adjusted independently.

1. Press and hold [Back].
2. Press [▲] to lighten the display, or press [▼] to darken the display.

8.4 Soft Starter Status LEDs

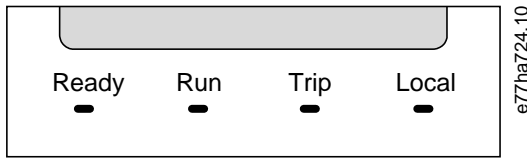

Illustration 26: Status LEDs on LCP

Table 27: LED Descriptions

LED name	On	Flashing
Ready	The motor is stopped and the soft starter is ready to start.	The motor is stopped and the soft starter is not ready to start: <ul style="list-style-type: none"> Waiting for the restart delay (<i>parameter 5-16 Restart Delay</i>). The thermal models indicate that the soft starter and/or motor are too hot to start safely. The reset input (RESET, COM+) is open.
Run	The motor is in run state (receiving full voltage).	The motor is starting or stopping.
Trip	The soft starter has tripped.	The soft starter is in warning state.
Local	The soft starter is controlled via a remote LCP.	–

If all LEDs are off, the soft starter is not receiving control voltage.

8.5 Displays

8.5.1 Soft Starter Information

At power-up, the soft starter information screen shows details of the soft starter rating, software versions, and serial number.

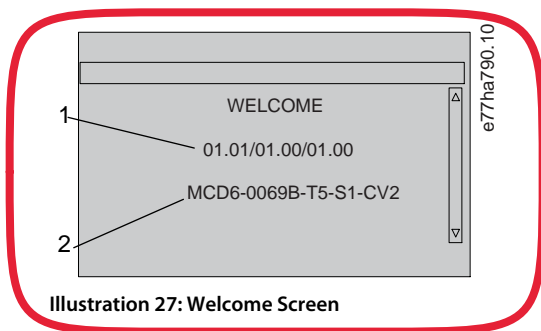

Illustration 27: Welcome Screen

- | | |
|---|---|
| 1 | Software versions: User interface, motor control, remote LCP (remote LCP software version is only shown when a remote LCP is connected) |
| 2 | Model code: Current rating, mains voltage, frame size, control voltage |

8.5.2 Configurable Feedback Screens

Select which information to show on the display. To switch between the 2 configurable screens, press [▲] and [▼].

8.5.3 Operating Feedback Screens

The operating feedback screens show the motor running current on the top half of the screen. To select which information is shown on the lower half, press [▲] and [▼].

- Real-time line current on each phase.
- Last start information.
- Date and time.

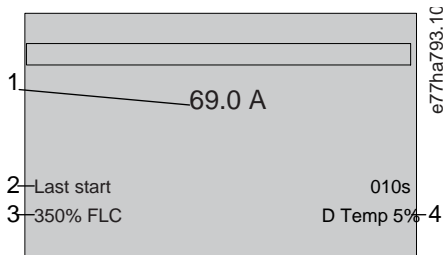
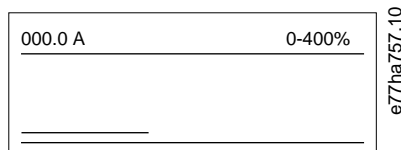

Illustration 28: Operating Feedback Screens

1	Motor running current	3	Maximum start current drawn (as a percentage of motor full load current)
2	Start duration (seconds)	4	Calculated rise in motor temperature

8.5.4 Performance Graph

The performance graph provides a real-time display of operating performance. Use *parameters 10-2 to 10-5* to format the graph. The display on the main LCP shows information for motor current.



If a remote LCP is connected, press [Graph] to change the graph data. The graph can show:

- Motor current.
- Motor temperature.
- Motor power factor.
- Analog input data from the smart card (if installed).

9 Operation

9.1 Start, Stop, and Reset Commands

The VLT® Soft Starter MCD 600 can be started and stopped via the digital inputs, remote LCP, communication network, smart card, or scheduled auto-start/stop. The command source can be set via the *Set-up Tools*, or by using *parameter 1-1 Command Source*.

- The MCD 600 only accepts start and reset commands from the designated command source.
- The MCD 600 accepts stop commands from the designated command source, but can be forced to stop by opening the reset input, or by opening the start/stop input during an auto-start/stop cycle.
- The programmable input can be used to override the selected command source (see *parameter 7-1 Input A Function*).

9.2 Command Override

The programmable input (DI-A, COM+) can be used to override the command source for situations where the normal control mechanism has been lost. Set *parameter 7-1 Input A Function* to the alternative control source (for example *Command Override: Keypad*).

While the input is active, the soft starter only accepts commands from the selected override source. To restore control to the command source selected in *parameter 1-1 Command Source*, reopen the input.

9.3 Auto-start/Stop

The soft starter can be configured to automatically start and/or stop the motor at a particular time, or run it in cycles of a specified duration.

NOTICE

Start delay, restart delay, and auto-reset delay all apply to auto-start operation.

9.3.1 Clock Mode

The soft starter can start and/or stop the motor once per day.

For clock mode to operate:

- *Parameter 4-1 Auto-Start/Stop Mode* must be set to *Enable*.
- *Parameter 1-1 Command Source* must be set to *Clock*.
- The reset input must be closed.
- The start input (START, COM+) must be active. This allows the soft starter to be stopped via the digital inputs in an emergency.

Clock mode operation is controlled by *parameters 4-4 to 4-24*.

9.3.2 Timer Mode

The soft starter can automatically stop the motor after a specified run-time, then restart it after a specified off (stopped) time. The soft starter repeats the cycle while the start signal remains active.

For timer mode to operate:

- *Parameter 4-1 Auto-Start/Stop Mode* must be set to *Enable*.
- *Parameter 1-1 Command Source* must be set to *Timer*.
- The reset input must be closed.
- The first start must be commanded by a start signal.

Timer mode operation is controlled by *parameters 4-2 to 4-3*.

9.4 PowerThrough

PowerThrough allows the soft starter to control the motor even if the soft starter is damaged on 1 phase. The VLT® Soft Starter MCD 600 uses 2-phase control techniques to soft start and soft stop the motor.

PowerThrough does not support adaptive control soft starting or soft stopping. In PowerThrough, the soft starter uses constant current soft starting and timed voltage ramp soft stopping. If Power Through is enabled, *parameters 2-3 and 2-4* must be set appropriately.

N O T I C E

The soft starter trips on *Lx-Tx Shorted* on the first start attempt after control power is applied. PowerThrough does not operate if control power is cycled between starts.

- PowerThrough is only available with in-line installations. If the soft starter is installed inside delta, PowerThrough will not operate.
- PowerThrough remains active until *3-Phase Control Only* is reselected. While operating in PowerThrough, the trip LED flashes and the display indicates *2 Phase - Damaged SCR*.

N O T I C E

PowerThrough uses a 2-phase soft start technology and extra care is required when sizing circuit breakers and protection. Contact the local supplier for assistance.

9.5 Emergency Mode

Emergency mode allows the soft starter to run the motor and ignore trip conditions.

Emergency mode is controlled via a programmable input (input A DI-A, COM+ or input B DI-B, COM+). *Parameter 7-1 Input A Function/parameter 7-5 Input B Function* must be set to *Emergency Mode*. A closed circuit across DI-A, COM+ activates emergency mode. When the soft starter receives a start command, it continues to run until a stop command is received, ignoring all trips and warnings.

Emergency mode can be used with any command source.

N O T I C E

Although emergency mode operation satisfies the functionality requirements of fire mode, Danfoss does not recommend its use in situations that require testing and/or compliance with specific standards as it is not certified.

N O T I C E

REDUCED EQUIPMENT LIFETIME

Continued use of emergency mode is not recommended. Emergency mode may compromise the soft starter and/or motor life as all protections and trips are disabled. Using the soft starter in emergency mode voids the product warranty.

- Do not run the soft starter in emergency mode continuously.

9.6 Auxiliary Trip

An external trip circuit (such as a low-pressure alarm switch for a pumping system) can be used to trip the soft starter and stop the motor. The external circuit is connected to a programmable input (input A DI-A, COM+ or input B DI-B, COM+). To control the behavior of the trip, set the following parameters:

- *Parameter 7-1 Input A Function*: Select *Input Trip (N/O)*.
- *Parameter 7-2 Input A Trip*: Set as required. For example, *Run Only* limits the input trip to when the soft starter is running only.
- *Parameter 7-3 Input A Trip Delay*: Sets a delay between the input activating and the soft starter tripping.
- *Parameter 7-4 Input A Initial Delay*: Sets a delay before the soft starter monitors the state of the input after the start signal. For example, a delay may be required to allow time for pipeline pressure to build up.
- *Parameter 7-10 Input A Name*: Select a name, for example *Input A Trip* (optional).

9.7 Typical Control Methods

The requirements for an application differ between each installation, but the methods listed below are often a good starting point for common applications.

Table 28: Typical Control Methods

Application	Start mode	Start ramp time [s]	Initial current (%FLC)	Current limit (%FLC)	Stop mode	Stop time [s]
Bow thruster	Constant current	5	100	400	Coast to stop	n/a
Centrifuge (separator)	Constant current	1	200	450	Coast to stop	n/a
Chipper	Constant current	1	200	450	Coast to stop	n/a
Compressor - reciprocating - loaded	Constant current	1	200	450	Coast to stop	n/a
Compressor - reciprocating - unloaded	Constant current	1	200	400	Coast to stop	n/a
Compressor - screw - loaded	Constant current	1	200	400	Coast to stop	n/a
Compressor - screw -. unloaded	Constant current	1	200	350	Coast to stop	n/a
Conveyor - horizontal	Constant current	5	200	400	TVR soft stop	10
Conveyor - inclined	Constant current	2	200	450	Coast to stop	n/a
Conveyor - vertical (bucket)	Constant current	2	200	450	Coast to stop	n/a
Crusher - cone	Constant current	1	200	350	Coast to stop	n/a
Crusher - jaw	Constant current	1	200	450	Coast to stop	n/a
Crusher - rotary	Constant current	1	200	400	Coast to stop	n/a
Debarker	Constant current	1	200	350	Coast to stop	n/a
Fan - axial (damped)	Constant current	1	200	350	Coast to stop	n/a
Fan - axial (undamped)	Constant current	1	200	450	Coast to stop	n/a
Fan - centrifugal (damped)	Constant current	1	200	350	Coast to stop	n/a
Fan - centrifugal (undamped)	Constant current	1	200	450	Coast to stop	n/a
Fan - high pressure	Constant current	1	200	450	Coast to stop	n/a
Mill - ball	Constant current	1	200	450	Coast to stop	n/a
Mill - hammer	Constant current	1	200	450	Coast to stop	n/a
Pump - bore	Adaptive control (early acceleration)	3	n/a	500	Adaptive control (late deceleration)	3
Pump - centrifugal	Adaptive control (early acceleration)	10	n/a	500	Adaptive control (late deceleration)	15
Pump - hydraulic	Constant current	2	200	350	Coast to stop	n/a
Pump - positive displacement	Adaptive control (constant acceleration)	10	n/a	400	Adaptive control (constant deceleration)	10

Application	Start mode	Start ramp time [s]	Initial current (%FLC)	Current limit (%FLC)	Stop mode	Stop time [s]
Pump - submersible	Adaptive control (early acceleration)	5	n/a	500	Adaptive control (late deceleration)	5
Saw - bandsaw	Constant current	1	200	450	Coast to stop	n/a
Saw - circular	Constant current	1	200	350	Coast to stop	n/a
Shredder	Constant current	1	200	450	Coast to stop	n/a

9.8 Soft Start Methods

9.8.1 Constant Current

Constant current is the traditional form of soft starting, which raises the current from 0 to a specified level and keeps the current stable at that level until the motor has accelerated.

Constant current starting is ideal for applications where the start current must be kept below a particular level.

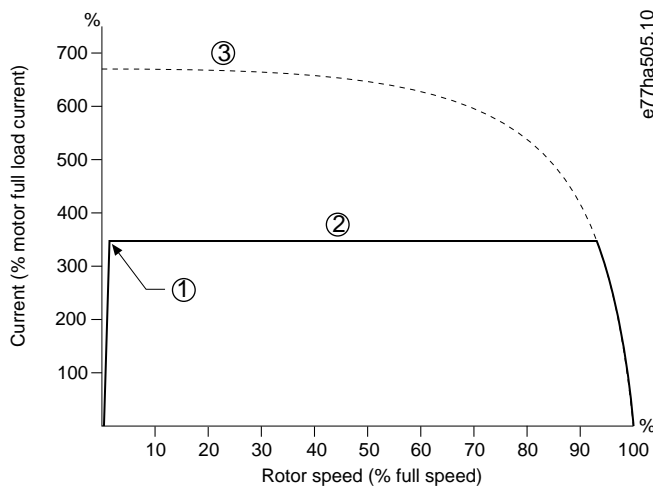

Illustration 29: Example of Constant Current

1	Initial current (set in <i>parameter 2-3 Initial Current</i>)	3	Full voltage current
2	Current limit (set in <i>parameter 2-4 Current Limit</i>)		

9.8.2 Constant Current with Current Ramp

Current ramp soft starting raises the current from a specified starting level (1) to a maximum limit (3) over an extended period (2).

Current ramp starting can be useful for applications where:

- The load can vary between starts (for example a conveyor which may start loaded or unloaded). Set *parameter 2-3 Initial Current* to a level that will start the motor with a light load. Then, set *parameter 2-4 Current Limit* to a level that will start the motor with a heavy load.
- The load breaks away easily, but starting time has to be extended (for example a centrifugal pump where pipeline pressure has to build up slowly).
- The electricity supply is limited (for example a generator set), and a slower application of load allows greater time for the supply to respond.

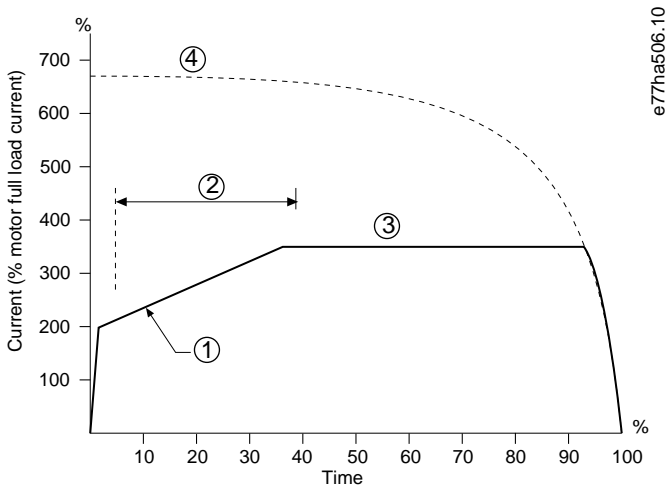

e77ha506.10

Illustration 30: Example of Current Ramp Soft Starting

1	Parameter 2-3 Initial Current	3	Parameter 2-4 Current Limit
2	Parameter 2-2 Start Ramp Time	4	Full voltage current

9.8.3 Constant Current with Kickstart

Kickstart provides a short boost of extra torque at the beginning of a start, and can be used with current ramp or constant current starting.

Kickstart can be useful to help start loads that require high breakaway torque but then accelerate easily (for example helical rotor pumps).

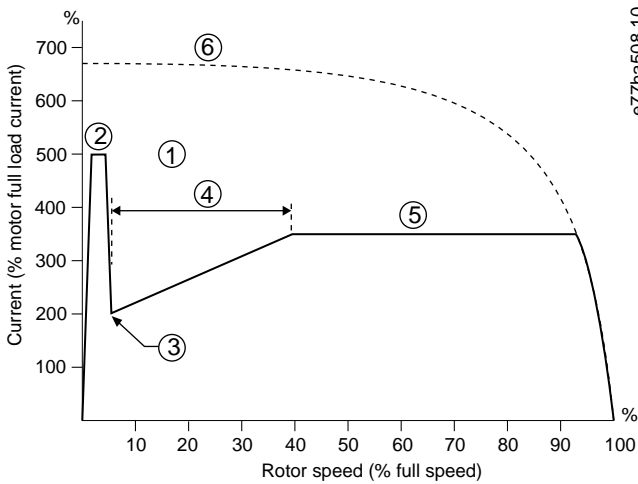

e77ha508.10

Illustration 31: Example of Kickstart used with Constant Current

1	Parameter 2-7 Kickstart Level	4	Parameter 2-2 Start Ramp Time
2	Parameter 2-6 Kickstart Time	5	Parameter 2-4 Current Limit
3	Parameter 2-3 Initial Current	6	Full voltage current

9.8.4 Timed Voltage Ramp

Timed voltage ramp (TVR) soft starting ramps the application of voltage to the motor over a defined time period. The voltage ramp reduces the initial starting torque and slows the motor's rate of acceleration.

TVR starting can be useful for applications where multiple motors of different sizes are connected in parallel, and/or the loads are not mechanically linked.

NOTICE

TVR soft starting is not suitable for high-inertia loads (such as fans), which require a high level of voltage to accelerate the load.

NOTICE

For multiple motors of the same size, and/or mechanically coupled loads, use constant current starting.

For a timed voltage ramp start, the following are typical values and can be adjusted to suit a specific application:

- Add the FLC value of all the connected motors. Use this combined value to set *parameter 1-2 Motor Full Load Current*.

NOTICE

The combined value must not exceed the soft starter rating.

- Set *parameter 2-3 Initial Current* to 100%, *parameter 2-4 Current Limit* to 500%, and set the ramp time as required (*parameter 2-2 Start Ramp Time*).

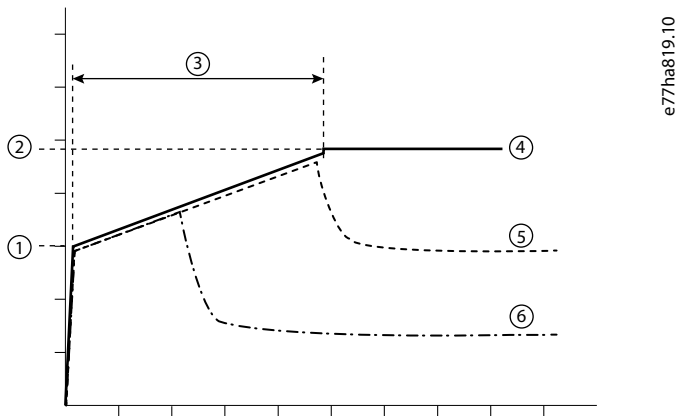

Illustration 32: Example of TVR

1	Initial current (parameter 2-3)	4	Full voltage
2	Current limit (parameter 2-4)	5	Motor 1 current
3	Start ramp time (parameter 2-2)	6	Motor 2 current

9.8.5 Adaptive Control for Starting

In an adaptive control soft start, the soft starter adjusts the current to start the motor within a specified time and uses a selected acceleration profile.

NOTICE

The soft starter applies the current limit on all soft starts, including adaptive control. If the current limit is too low or the start ramp time (set in *parameter 2-2 Start Ramp Time*) is too short, the motor may not start successfully.

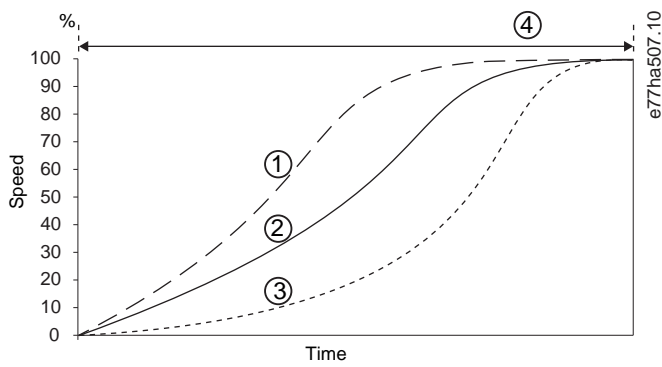

Illustration 33: Example of Adaptive Control Start (Parameter 2-5 Adaptive Start Profile)

1	Early acceleration	3	Late acceleration
2	Constant acceleration	4	Parameter 2-2 Start Ramp Time

9.8.5.1 Fine-tuning Adaptive Control

If the motor does not start or stop smoothly, adjust *parameter 2-12 Adaptive Control Gain*. The gain setting determines how much the soft starter adjusts future adaptive control starts and stops, based on information from the previous start. The gain setting affects both starting and stopping performance.

- If the motor accelerates or decelerates too quickly at the end of a start or stop, increase the gain setting by 5–10%.
- If the motor speed fluctuates during starting or stopping, decrease the gain setting slightly.

NOTICE

The soft starter tunes adaptive control to match the motor. Changing the following parameters resets adaptive control and the first start/stop cycle uses constant current start/timed voltage ramp stop: *Parameter 1-2 Motor Full Load Current*, *parameter 2-4 Current Limit*, and *parameter 2-12 Adaptive Gain*.

9.9 Stop Methods

9.9.1 Coast to Stop

Coast to stop lets the motor slow at its natural rate with no control from the soft starter. The time required to stop depends on the type of load.

9.9.2 Timed Voltage Ramp

Timed voltage ramp (TVR) reduces the voltage to the motor gradually over a defined time. This can extend the stopping time of the motor and may avoid transients on generator set supplies.

NOTICE

The load may continue to run after the stop ramp is complete.

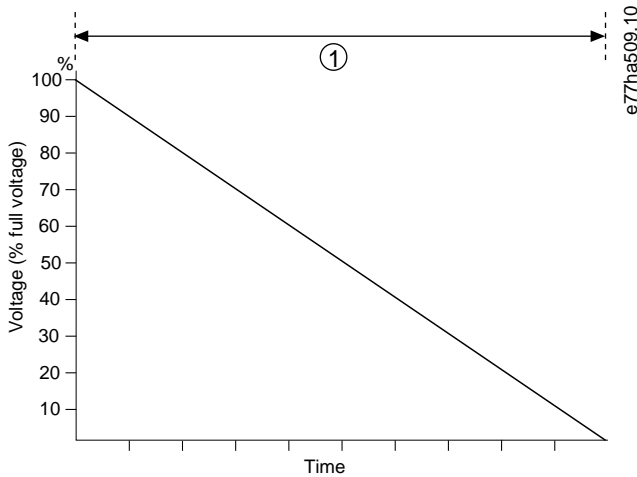

Illustration 34: Example of TVR

1	Parameter 2-10 Stop Time
---	--------------------------

9.9.3 Adaptive Control for Stopping

In an adaptive control soft stop, the soft starter controls the current to stop the motor within a specified time and uses a selected deceleration profile. Adaptive control can be useful in extending the stopping time of low inertia loads.

If adaptive control is selected, the first soft stop uses TVR. This allows the soft starter to learn the characteristics of the connected motor. This motor data is used by the soft starter during subsequent adaptive control stops.

NOTICE

Adaptive control does not actively slow the motor down and does not stop the motor faster than a coast to stop. To shorten the stopping time of high inertia loads, use brake.

NOTICE

Adaptive control controls the motor's speed profile within the programmed time limit. This may result in a higher level of current than traditional control methods.

If replacing a motor connected to a soft starter programmed for adaptive control starting or stopping, the soft starter has to learn the characteristics of the new motor. Change the value of *parameter 1-2 Motor Full Load Current* or *parameter 2-12 Adaptive Control Gain* to initiate the relearning process. The next start will use constant current and the next stop will use TVR.

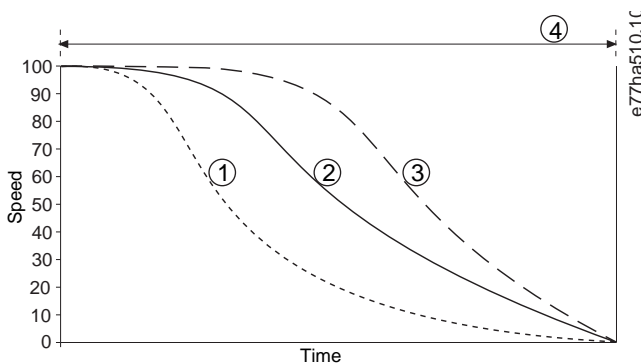

Illustration 35: Example of Adaptive Control Stop (Parameter 2-11 Adaptive Stop Profile)

1	Early deceleration	3	Late deceleration
2	Constant deceleration	4	Parameter 2-10 Stop Time

Adaptive control is ideal for pumping applications where it can minimize the damaging effects of fluid hammer. Test the 3 profiles to identify the best profile for the application.

Adaptive stop profile	Application
Late deceleration	High-head systems where even a small decrease in motor/pump speed results in a rapid transition between forward flow and reverse flow.
Constant deceleration	Low to medium head, high-flow applications where the fluid has high momentum.
Early deceleration	Open pump systems where fluid must drain back through the pump without driving the pump in reverse.

9.9.4 DC Brake

A brake reduces the time required to stop the motor.

During braking, an increased noise level from the motor may be audible. This is a normal part of motor braking.

N O T I C E

When using DC brake, the mains supply must be connected to the soft starter (input terminals L1, L2, and L3) in positive phase sequence.

N O T I C E

MOTOR DAMAGE

If the brake torque setting is too high, the motor stops before the end of the brake time and the motor suffers unnecessary heating, which could result in damage. A high brake torque setting can also result in peak currents up to motor DOL being drawn while the motor is stopping.

- Careful configuration is required to ensure safe operation of the soft starter and the motor.
- Ensure that protection fuses installed in the motor branch circuit are selected appropriately.

N O T I C E

RISK OF OVERHEATING

Brake operation causes the motor to heat faster than the rate calculated by the motor thermal model.

- Install a motor thermistor or allow sufficient restart delay (set in *parameter 5-16 Restart Delay*).

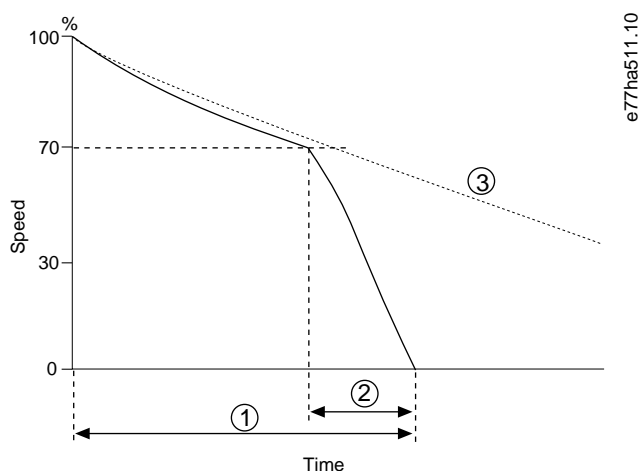

Illustration 36: Example of Brake Time

<p>1 <i>Parameter 2-10 Stop Time</i></p> <p>2 <i>Parameter 2-16 Brake Time</i></p>	<p>3 <i>Coast to stop time</i></p>
--	---

Parameter settings:

- *Parameter 2-9 Stop Mode:* Set to *DC Brake*.
- *Parameter 2-10 Stop Time:* This is the total braking time (1) and must be set sufficiently longer than the brake time (in *parameter 2-16 DC Brake Time*) to allow the prebraking stage to reduce motor speed to approximately 70%. If the stop time is too short, braking will not be successful and the motor will coast to stop.
- *Parameter 2-15 DC Brake Torque:* Set as required to slow the load. If set too low, the motor will not stop completely and will coast to stop after the end of the braking period.
- *Parameter 2-16 DC Brake Time:* Set this parameter to approximately 1 quarter of the programmed stop time. This sets the time for the full brake stage (2).

9.9.5 Soft Brake

For applications with high inertia and/or variable load requiring the maximum possible brake power, the soft starter can be configured for soft braking.

The soft starter uses a changeover relay to control forward run and braking contactors. While braking, the soft starter reverses the phase sequence to the motor and supplies reduced current, gently slowing the load.

When motor speed approaches 0, the zero-speed sensor (A2) stops the soft starter and opens the braking contactor (K2).

Soft braking can be used with both the primary and secondary motor sets and must be configured separately for each.

Parameter settings:

- *Parameter 2-9 Stop Mode:* Set to *Soft Brake*.
- *Parameter 2-17 Brake Current Limit:* Set as required to slow the load.
- *Parameter 2-18 Soft Brake Delay:* Controls the time the soft starter waits after a stop signal is received, before it begins to supply braking current to the motor. Set to allow time for K1 and K2 to switch.
- *Parameter 7-1 Input A Function:* Set to *Zero Speed Sensor*.
- *Parameter 8-1 Relay A Function:* Set to *Soft Brake Relay*.

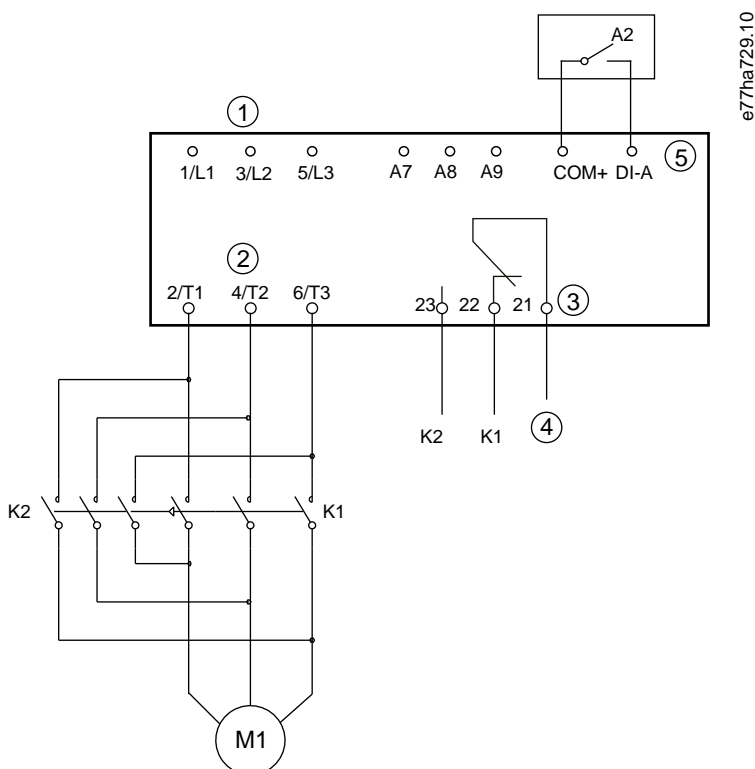

Illustration 37: Wiring Example of Soft Braking

1	Three-phase supply	5	Programmable input A
2	Motor terminals	K1	Line contactor (Run)
3	Relay A output	K2	Line contactor (Brake)
4	K1/K2 coil supply	A2	Zero-speed sensor

9.10 Pump Clean

The soft starter can perform a pump clean function before soft starting the motor. This can help dislodge debris from the impeller. Pump clean starts the motor in reverse then forward direction, then stops the motor. Pump clean can be configured to repeat the process up to 5 times. After the specified number of cleaning cycles, the soft starter performs the programmed soft start.

Pump clean operation is controlled by the start/stop input (START, COM+). Set a programmable input to pump clean (see *parameter 7-1 Input A Function* for details). Ensure that the input is closed when the start signal is applied.

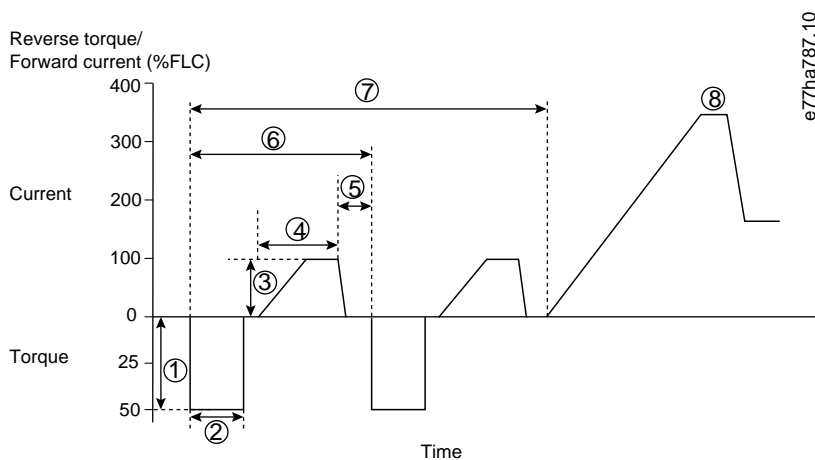

Illustration 38: Pump Clean

1	Parameter 11-1 Reverse Torque	5	Parameter 11-6 Pump Stop Time
2	Parameter 11-2 Reverse Time	6	Cleaning cycle
3	Parameter 11-3 Forward Current Limit	7	Parameter 11-7 Pump Clean Cycles
4	Parameter 11-4 Forward Time	8	Programmed soft start

9.11 Reverse Direction Operation

The soft starter can control a reversing contactor to operate the motor in reverse direction. When reverse operation is selected, the soft starter performs a soft start using the opposite phase sequence from normal operation.

Reverse operation is controlled by the start/stop input (START, COM+). Set a programmable input to reverse direction (*parameter 7-1 Input A Function*) and set an output to reversing contactor (*parameter 8-1 Relay A Function*).

The input must be closed when the start signal is applied. The soft starter keeps the reverse relay in the same state until the end of the starting/stopping cycle.

The following example is a simple installation, but many different configurations are possible depending on the application requirements. Contact a local supplier for an application note showing more installation options.

NOTICE

The first start after the direction is changed will be constant current.

NOTICE

If phase sequence protection is required, install the reversing contactor on the output (motor) side of the soft starter.

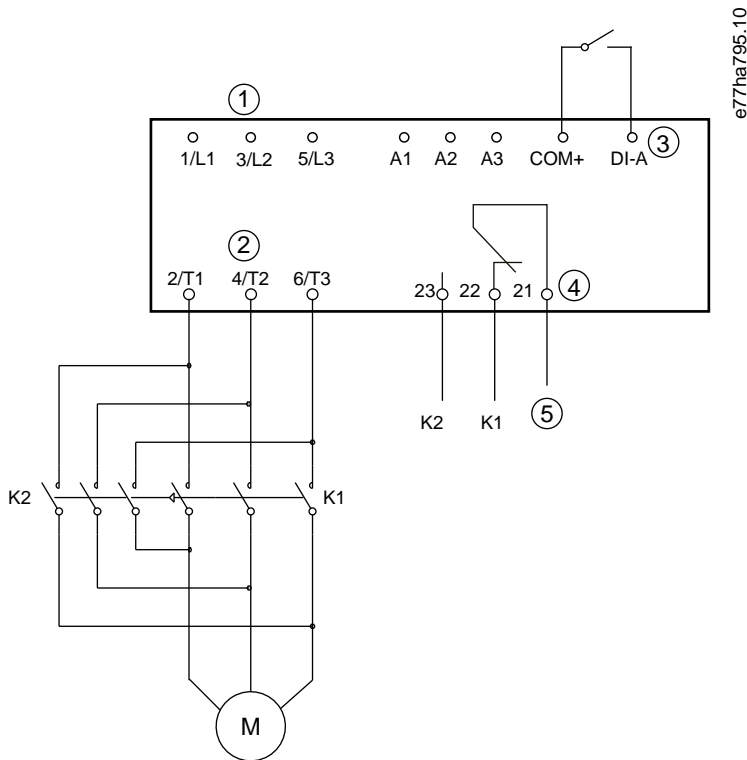

Illustration 39: Connection Diagram

1	Three-phase supply	5	K1/K2 coil supply
2	Motor terminals	K1	Forward run contactor
3	Programmable input A (set=Reverse direction)	K2	Reversing contactor
4	Relay output A (set=Reversing contactor)		

9.12 Jog Operation

Jog runs the motor at reduced speed to allow alignment of the load or to assist servicing. The motor can be jogged in either forward or reverse direction.

Jog is only available when the soft starter is controlled via the digital inputs (*parameter 1-1 Command Source* set to *Digital Input*). To operate in jog, set a programmable input to jog (see *parameter 7-1 Input A Function* for details). Ensure that the input is closed when the start signal is applied.

NOTICE

REDUCED MOTOR COOLING

Slow speed running is not intended for continuous operation due to reduced motor cooling. Jog operation causes the motor to heat faster than the rate calculated by the motor thermal model.

- Install a motor thermistor or allow sufficient restart delay (*parameter 5-16 Restart Delay*).

The maximum available torque for jog forward is approximately 50–75% of motor FLT depending on the motor. When the motor is jogged in reverse, the torque is approximately 25–50% of FLT.

Parameter 2-8 Jog Torque and *parameter 3-10 Jog Torque-2* control how much of the maximum available jog torque the soft starter applies to the motor.

NOTICE

Torque settings above 50% may cause increased shaft vibration.

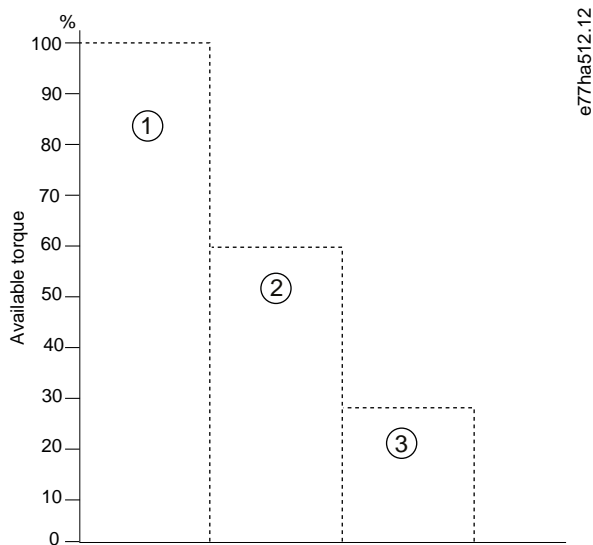

Illustration 40: Available Torque in Jog Operation

1	Motor FLT	3	Jog reverse maximum torque
2	Jog forward maximum torque		

9.13 Inside Delta Operation

When connecting in inside delta, enter the value of the FLC in *parameter 1-2 Motor Full Load Current*. The soft starter automatically detects whether the motor is connected in-line or inside delta and calculates the correct inside delta current level.

Adaptive control, jog, brake, and PowerThrough functions are not supported with inside delta (6-wire) operation. If these functions are programmed when the soft starter is connected inside delta, the behavior is given as below.

Adaptive control start	The soft starter performs a constant current start.
Adaptive control stop	The soft starter performs a TVR soft stop if <i>parameter 2-10 Stop Time</i> is >0 s. If <i>parameter 2-10 Stop Time</i> is set to 0 s, the soft starter performs a coast to stop.
Jog	The soft starter issues a warning with the error message <i>Unsupported option</i> .
DC brake	The soft starter performs a coast to stop.
Soft brake	The soft starter performs a coast to stop.
PowerThrough	The soft starter trips with the error message <i>Lx-Tx Shorted</i> .

NOTICE

When connected in inside delta, the soft starter does not detect phase loss on T2 during run.

NOTICE

If the soft starter is not correctly detecting the motor connection, use *parameter 20-6 Motor Connection*.

9.14 Secondary Motor Set

The soft starter can be programmed with 2 separate starting and stopping profiles. This allows the soft starter to control the motor in 2 different starting and stopping configurations. The secondary motor set is ideal for dual winding (Dahlander) motors, multi-motor applications, or situations where the motor may start in 2 different conditions (such as loaded and unloaded conveyors). The secondary motor set can also be used for duty/standby applications.

NOTICE

For duty/standby applications, set *parameter 6-17 Motor Overtemperature* to *Log Only* and install temperature protection for each motor.

To use the secondary motor set, set a programmable input to *Motor Set Select*. The input must be closed when a start command is given (see *parameter 7-1 Input A Function* and *parameter 7-5 Input B Function*). The soft starter checks which motor set to use at start and uses that motor set for the entire start/stop cycle.

The soft starter uses the secondary motor settings to control a start when instructed via a programmable input (see *parameter 7-1 Input A Function* and *parameter 7-5 Input B Function*).

10 Programmable Parameters

10.1 Main Menu

Use the Main Menu to view and change programmable parameters that control how the soft starter operates.

To open the Main Menu, press [Menu/Store], scroll to Main Menu, and press [Menu/Store] again.

N O T I C E

Parameters for smart card functions are only visible in the parameter list if the smart card is installed.

10.2 Changing Parameter Values

Procedure

1. Scroll to the parameter in the Main Menu.
2. Press [Menu/Store] to enter edit mode.
3. Press [▲] or [▼] to change parameter settings.

Pressing [▲] or [▼] once increases or decreases the value by 1 unit. If the key is held for longer than 5 s, the value increases or decreases at a faster rate.

- Press [Store] to save changes. The setting shown on the display is saved and the LCP returns to the parameter list.
- Press [Back] to cancel changes. The LCP asks for confirmation, then returns to the parameter list without saving the changes.

10.3 Adjustment Lock

Use *parameter 10-7 Adjustment Lock* to prevent users from changing parameter settings.

If a user attempts to change a parameter value when the adjustment lock is active, the following error is shown: *Access Denied. Adj Lock is On.*

10.4 Parameter List

Table 29: Parameter List

Parameter group number	Parameter group name	Default setting
1	Motor Details	
1-1	Command Source	Digital Input
1-2	Motor Full Load Current	Model dependent
1-3	Motor kW	0 kW
1-4	Locked Rotor Time	00:10 (mm:ss)
1-5	Locked Rotor Current	600%
1-6	Motor Service Factor	105%
1-7	Reserved	–
2	Motor Start/Stop	
2-1	Start Mode	Constant Current
2-2	Start Ramp Time	00:10 (mm:ss)
2-3	Initial Current	200%
2-4	Current Limit	350%
2-5	Adaptive Start Profile	Constant Acceleration

Parameter group number	Parameter group name	Default setting
2-6	Kickstart Time	000 ms
2-7	Kickstart Level	500%
2-8	Jog Torque	50%
2-9	Stop Mode	TVR Soft Stop
2-10	Stop Time	00:00 (mm:ss)
2-11	Adaptive Stop Profile	Constant Deceleration
2-12	Adaptive Control Gain	75%
2-13	Multi Pump	Single Pump
2-14	Start Delay	00:00 (mm:ss)
2-15	DC Brake Torque	20%
2-16	DC Brake Time	00:01 (mm:ss)
2-17	Brake Current Limit	250%
2-18	Soft Brake Delay	400 ms
3	Motor Start/Stop 2	
3-1	Motor Full Load Current-2	Model dependent
3-2	Motor kW-2	0 kW
3-3	Start Mode-2	Constant Current
3-4	Start Ramp Time-2	00:10 (mm:ss)
3-5	Initial Current-2	200%
3-6	Current Limit-2	350%
3-7	Adaptive Start Profile-2	Constant Acceleration
3-8	Kickstart Time-2	000 ms
3-9	Kickstart Level-2	500%
3-10	Jog Torque-2	50%
3-11	Stop Mode-2	TVR Soft Stop
3-12	Stop Time-2	00:00 (mm:ss)
3-13	Adaptive Stop Profile-2	Constant Deceleration
3-14	Adaptive Control Gain-2	75%
3-15	Multi Pump-2	Single Pump
3-16	Start Delay-2	00:00 (mm:ss)
3-17	DC Brake Torque-2	20%
3-18	DC Brake Time-2	00:01 (mm:ss)

Parameter group number	Parameter group name	Default setting
3-19	Brake Current Limit-2	250%
3-20	Soft Brake Delay-2	400 s
4	Auto-Start/Stop	
4-1	Auto-Start/Stop Mode	Disable
4-2	Run Time	00:00 (hh:mm)
4-3	Stopped Time	00:00 (hh:mm)
4-4	Sunday Mode	Start/Stop Disable
4-5	Sunday Start Time	00:00 (hh:mm)
4-6	Sunday Stop Time	00:00 (hh:mm)
4-7	Monday Mode	Start/Stop Disable
4-8	Monday Start Time	00:00 (hh:mm)
4-9	Monday Stop Time	00:00 (hh:mm)
4-10	Tuesday Mode	Start/Stop Disable
4-11	Tuesday Start Time	00:00 (hh:mm)
4-12	Tuesday Stop Time	00:00 (hh:mm)
4-13	Wednesday Mode	Start/Stop Disable
4-14	Wednesday Start Time	00:00 (hh:mm)
4-15	Wednesday Stop Time	00:00 (hh:mm)
4-16	Thursday Mode	Start/Stop Disable
4-17	Thursday Start Time	00:00 (hh:mm)
4-18	Thursday Stop Time	00:00 (hh:mm)
4-19	Friday Mode	Start/Stop Disable
4-20	Friday Start Time	00:00 (hh:mm)
4-21	Friday Stop Time	00:00 (hh:mm)
4-22	Saturday Mode	Start/Stop Disable
4-23	Saturday Start Time	00:00 (hh:mm)
4-24	Saturday Stop Time	00:00 (hh:mm)
5	Protection Levels	
5-1	Current Imbalance	30%
5-2	Current Imbalance Delay	00:03 (mm:ss)
5-3	Undercurrent	20%
5-4	Undercurrent Delay	00:05 (mm:ss)

Parameter group number	Parameter group name	Default setting
5-5	Overcurrent	400%
5-6	Overcurrent Delay	00:00 (mm:ss)
5-7	Undervoltage	350 V
5-8	Undervoltage Delay	00:01 (mm:ss)
5-9	Overvoltage	500 V
5-10	Overvoltage Delay	00:01 (mm:ss)
5-11	Underpower	10%
5-12	Underpower Delay	00:01 (mm:ss)
5-13	Overpower	150%
5-14	Overpower Delay	00:01 (mm:ss)
5-15	Excess Start Time	00:20 (mm:ss)
5-16	Restart Delay	00:10 (mm:ss)
5-17	Starts per Hour	0
5-18	Phase Sequence	Any Sequence
6	Protection Actions	
6-1	Auto-Reset Count	0
6-2	Auto-Reset Delay	00:05 (mm:ss)
6-3	Current Imbalance	Soft Trip and Log
6-4	Undercurrent	Soft Trip and Log
6-5	Overcurrent	Soft Trip and Log
6-6	Undervoltage	Soft Trip and Log
6-7	Overvoltage	Soft Trip and Log
6-8	Underpower	Log Only
6-9	Overpower	Log Only
6-10	Excess Start Time	Soft Trip and Log
6-11	Input A Trip	Soft Trip and Log
6-12	Input B Trip	Soft Trip and Log
6-13	Network Communications	Soft Trip and Log
6-14	Remote Keypad Fault	Soft Trp and Log
6-15	Frequency	Soft Trip and Log
6-16	Phase Sequence	Soft Trip and Log
6-17	Motor Overtemperature	Soft Trip and Log

Parameter group number	Parameter group name	Default setting
6-18	Motor Thermistor Circuit	Soft Trip and Log
6-19	Shorted SCR Action	3-Phase Control Only
6-20	Battery/Clock	Soft Trip and Log
7	Inputs	
7-1	Input A Function	Input Trip (N/O)
7-2	Input A Trip	Operating Only
7-3	Input A Trip Delay	00:00 (mm:ss)
7-4	Input A Initial Delay	00:00 (mm:ss)
7-5	Input B Function	Input Trip (N/O)
7-6	Input B Trip	Operating Only
7-7	Input B Trip Delay	00:00 (mm:ss)
7-8	Input B Initial Delay	00:00 (mm:ss)
7-9	Reset/Enable Logic	Normally Closed (N/C)
7-10	Input A Name	Input A Trip
7-11	Input B Name	Input B Trip
8	Relay Outputs	
8-1	Relay A Function	Run
8-2	Relay A On Delay	00:00 (mm:ss)
8-3	Relay A Off Delay	00:00 (mm:ss)
8-4	Relay B Function	Run
8-5	Relay B On Delay	00:00 (mm:ss)
8-6	Relay B Off Delay	00:00 (mm:ss)
8-7	Low Current Flag	50%
8-8	High Current Flag	100%
8-9	Motor Temperature Flag	80%
8-10	Main Contactor Time	400 ms
9	Analog Output	
9-1	Analog Output A	Current (% FLC)
9-2	Analog A Scale	4–20 mA
9-3	Analog A Maximum Adjustment	100%
9-4	Analog A Minimum Adjustment	000%
10	Display	

Parameter group number	Parameter group name	Default setting
10-1	Language	English
10-2	Temperature Scale	Celsius
10-3	Graph Timebase	30 s
10-4	Graph Maximum Adjustment	400%
10-5	Graph Minimum Adjustment	0%
10-6	Current Calibration	100%
10-7	Adjustment Lock	Read & Write
10-8	User Parameter 1	Current
10-9	User Parameter 2	Motor Voltage
10-10	User Parameter 3	Mains Frequency
10-11	User Parameter 4	Motor pf
10-12	User Parameter 5	Motor Power
10-13	User Parameter 6	Motor Temp (%)
11	Pump Clean	
11-1	Reverse Torque	20%
11-2	Reverse Time	00:10 (mm:ss)
11-3	Forward Current Limit	100%
11-4	Forward Time	00:10 (mm:ss)
11-5	Pump Stop Mode	Coast to Stop
11-6	Pump Stop Time	00:10 (mm:ss)
11-7	Pump Clean Cycles	1
12	Communication Card	
12-1	Modbus Address	1
12-2	Modbus Baud Rate	9600
12-3	Modbus Parity	None
12-4	Modbus Timeout	Off
12-5	DeviceNet Address	0
12-6	DeviceNet Baud Rate	125 kB
12-7	PROFIBUS Address	1
12-8	Gateway Address	192
12-9	Gateway Address 2	168
12-10	Gateway Address 3	0

Parameter group number	Parameter group name	Default setting
12-11	Gateway Address 4	100
12-12	IP Address	192
12-13	IP Address 2	168
12-14	IP Address 3	0
12-15	IP Address 4	2
12-16	Subnet Mask	255
12-17	Subnet Mask 2	255
12-18	Subnet Mask 3	255
12-19	Subnet Mask 4	0
12-20	DHCP	Disable
12-21	Location ID	0
20	Advanced	
20-1	Tracking Gain	50%
20-2	Pedestal Detect	80%
20-3	Bypass Contactor Delay	100 ms
20-4	Model Rating	Model dependent
20-5	Screen Timeout	1 minute
20-6	Motor Connection	Auto-detect
20-7	External Bypass	Disable
20-8	Shunt Trip Mode	Disable
30	Pump Input Configuration	
30-1	Pressure Sensor Type	None
30-2	Pressure Units	kPa
30-3	Pressure at 4 mA	0
30-4	Pressure at 20 mA	0
30-5	Flow Sensor Type	None
30-6	Flow Units	liters/second
30-7	Flow at 4 mA	0
30-8	Flow at 20 mA	0
30-9	Units per Minute at Max Flow	0
30-10	Pulses per Minute at Max Flow	0
30-11	Units per Pulse	0

Parameter group number	Parameter group name	Default setting
30-12	Depth Sensor Type	None
30-13	Depth Units	meters
30-14	Depth at 4 mA	0
30-15	Depth at 20 mA	0
31	Flow Protection	
31A	High Flow Trip Level	10
31B	Low Flow Trip Level	5
31C	Flow Start Delay	00:00:500 (mm:ss:ms)
31D	Flow Response Delay	00:00:500 (mm:ss:ms)
32	Pressure Protection	
32-1	High Pressure Trip Level	10
32-2	High Pressure Start Delay	00:00:500 (mm:ss:ms)
32-3	High Pressure Response Delay	00:00:500 (mm:ss:ms)
32-4	Low Pressure Trip Level	5
32-5	Low Pressure Start Delay	00:00:500 (mm:ss:ms)
32-6	Low Pressure Response Delay	00:00:500 (mm:ss:ms)
33	Pressure Control	
33-1	Pressure Control Mode	Off
33-2	Start Pressure Level	5
33-3	Start Response Delay	00:00:500 (mm:ss:ms)
33-4	Stop Pressure Level	10
33-5	Stop Response Delay	00:00:500 (mm:ss:ms)
34	Depth Protection	
34-1	Depth Trip Level	5
34-2	Depth Reset Level	10
34-3	Depth Start Delay	00:00:500 (mm:ss:ms)
34-4	Depth Response Delay	00:00:500 (mm:ss:ms)
35	Thermal Protection	
35-1	Temperature Sensor Type	None
35-2	Temperature Trip Level	40
36	Pump Trip Action	
36-1	Pressure Sensor	Soft Trip and Log

Parameter group number	Parameter group name	Default setting
36-2	Flow Sensor	Soft Trip and Log
36-3	Depth Sensor	Soft Trip and Log
36-4	High Pressure	Soft Trip and Log
36-5	Low Pressure	Soft Trip and Log
36-6	High Flow	Soft Trip and Log
36-7	Low Flow	Soft Trip and Log
36-8	Flow Switch	Soft Trip and Log
36-9	Well Depth	Soft Trip and Log
36-10	RTD/PT100 B	Soft Trip and Log
40	Ground Fault	
40-1	Ground Fault Level	0 A
40-2	Ground Fault Delay	00:01 (mm:ss)
40-3	Ground Fault Trip Active	Operating only
40-4	Ground Fault Action	Soft Trip and Log
40-5	Ground Fault CT Ratio	1000:1

10.5 Parameter Group 1-** Motor Details

Table 30: 1-1 - Command Source

Option	Function
	Selects the command source for controlling the soft starter.
* Digital input	The soft starter accepts start and stop commands from the digital inputs.
Network	The soft starter accepts start and stop commands from the communication expansion card.
Remote LCP	The soft starter accepts start and stop commands from the remote LCP.
Clock	The soft starter accepts starts and stops as scheduled in <i>parameters 4-1 to 4-24</i> .
Smart card	The soft starter accepts start and stop commands from the smart card.
Smart card + clock	The soft starter accepts start commands from the smart card if they are within the operating schedule set in <i>parameters 4-1 to 4-24</i> . A stop command from the smart card is accepted regardless of the schedule.
Timer	After a start signal is received, the soft starter starts and stops the motor according to the timers set in <i>parameter 4-2 Run Time</i> and <i>parameter 4-3 Stopped Time</i> .

Table 31: 1-2 Motor Full Load Current

Range	Function
Model dependent	Matches the soft starter to the FLC of the motor. Set to the FLC rating shown on the motor nameplate.

Table 32: 1-3 Motor kW

Range		Function
*0	0–9999 kW	Sets the running power of the connected motor in kW. This setting is the basis for power reporting and protection.
NOTICE		
The motor nameplate may state different power ratings for different supply voltages or power connections. Ensure that the motor kW setting is accurate for the installation.		

Table 33: 1-4 Locked Rotor Time

Range		Function
*10 s	0:01–2:00 (minutes:seconds)	Sets the maximum length of time the motor can sustain locked rotor current from cold before reaching its maximum temperature. Set according to the motor datasheet.

Table 34: 1-5 Locked Rotor Current

Range		Function
*600%	400–1200% FLC	Sets the locked rotor current of the connected motor as a percentage of full load current. Set according to the motor datasheet.

Table 35: 1-6 Motor Service Factor

Range		Function
*105%	100–130%	Sets the motor service factor used by the thermal model. If the motor runs at full load current, it reaches 100%. Set according to the motor datasheet.
NOTICE		
<i>Parameters 1-4 to 1-6 determine the trip current for motor overload protection. The default settings of parameters 1-4 to 1-6 provide motor overload protection: Class 10, trip current 105% of FLA (full load amperage) or equivalent.</i>		

Table 36: 1-7 Reserved

Range		Function
		This parameter is reserved for future use.

10.6 Parameter Group 2-** Motor Start/Stop

Table 37: 2-1 - Start Mode

Option	Function
	Selects the soft start mode. <div style="text-align: center;">NOTICE</div> The VLT® Soft StarterMCD 600 applies the current limit on all soft starts, including adaptive control. If the current limit is too low or the start ramp time (<i>parameter 2-2 Start Ramp Time</i>) is too short, the motor may not start successfully.
*	Constant Current

Option	Function
Adaptive Control	

Table 38: 2-2 - Start Ramp Time

Range	Function
* 10 s	0:01–3:00 (minutes:seconds)
	3.(2) 0.01 – 180 Sec. Sets the total start time for an adaptive control start or the ramp time for current ramp starting (from the initial current to the current limit).

Table 39: 2-3 - Initial Current

Range	Function
* 200%	100–600% FLC
	Sets the initial start current level for current ramp starting as a percentage of motor full load current. Set so that the motor begins to accelerate immediately after a start is initiated. If current ramp starting is not required, set the initial current equal to the current limit.

Table 40: 2-4 - Current Limit

Range	Function
* 350%	100–600% FLC
	3.(2) 100 – 600%. Sets the current limit for constant current and current ramp soft starting as a percentage of motor full load current.

Table 41: 2-5 - Adaptive Start Profile

Option	Function
	<p>Selects which profile the VLT® Soft StarterMCD 600 uses for an adaptive control soft start.</p> <div style="border: 1px solid black; padding: 5px; text-align: center;"> <p>NOTICE</p> <p>The MCD 600 applies the current limit on all soft starts, including adaptive control. If the current limit is too low or the start ramp time (<i>parameter 2-2 Start Ramp Time</i>) is too short, the motor may not start successfully.</p> </div>
	Early Acceleration
*	Constant Acceleration
	Late Acceleration

Table 42: 2-6 - Kickstart Time

Range	Function
* 0000 ms	0–2000 ms
	Sets the kickstart duration. A setting of 0 disables kickstart.

Table 43: 2-7 - Kickstart Level

Range	Function
* 500%	100–700% FLC
	<p>Sets the level of the kickstart current.</p> <div style="border: 1px solid black; padding: 5px; text-align: center;"> <p>NOTICE</p> <p>Kickstart subjects the mechanical equipment to increased torque levels. Ensure that the motor, load, and couplings can handle the additional torque before using this feature.</p> </div>

Table 44: 2-8 - Jog Torque

Range		Function
* 50%	20–100%	The VLT® Soft Starter MCD 600 can jog the motor at a reduced speed, which allows precise positioning of belts and flywheels. Jog can be used for either forward or reverse operation. Set the current limit for jog operation.

Table 45: 2-9 - Stop Mode

Option	Function
	Selects the stop mode.
	Coast To Stop
*	TVR Soft Stop
	Adaptive Control
	DC Brake
	Soft Brake

Table 46: 2-10 - Stop Time

3. (2) 0-240Sec.

Range		Function
* 0 s	0:00–4:00 (minutes:seconds) *	Sets the time for soft stopping the motor using TVR or adaptive control. If a main contactor is installed, the contactor must remain closed until the end of the stop time. Use the main contactor output (13, 14) to control the main contactor.

Table 47: 2-11 - Adaptive Stop Profile

Option	Function
	Selects which profile the VLT® Soft Starter MCD 600 uses for an adaptive control soft stop.
	Early Deceleration
*	Constant Deceleration
	Late Deceleration

Table 48: 2-12 - Adaptive Control Gain

Range		Function
* 75%	1–200%	Adjusts the performance of adaptive control. This setting affects both starting and stopping control.

Table 49: 2-13 - Multi Pump

Option	Function
	Adjusts the performance of adaptive control to suit installations with multiple pumps connected to a common outlet manifold.
*	Single Pump
	Manifold Pump

Table 50: 2-14 - Start Delay

Range		Function
* 0 s	0:00–60:00 (minutes:seconds)	Sets a delay after the soft starter receives a start command before it starts the motor.

Table 51: 2-15 - DC Brake Torque

Range		Function
* 20%	20–100%	Sets the amount of brake torque the soft starter uses to slow the motor.

Table 52: 2-16 - DC Brake Time

Range		Function
* 1 s	0:01–0:30 (minutes:seconds)	Sets the duration for DC injection during a braking stop.

Table 53: 2-17- Brake Current Limit

Range		Function
* 250%	100–600% FLC	Sets the current limit for soft brake.

Table 54: 2-18 - Soft Brake Delay

Range		Function
*400 ms	400–2000 ms	Sets the time which the soft starter waits after a stop signal is received before it begins to supply braking current to the motor. Set to allow time for K1 and K2 to switch.

10.7 Parameter Group 3-** Motor Start/Stop-2

The parameters in this group control the operation of the secondary configuration of the motor. Use the programmable input to select the active motor set.

See [9.14 Secondary Motor Set](#) for more details.

Table 55: 3-1 - Motor Full Load Current-2

Range		Function
	Model dependent	Sets the secondary motor's full load current.

Table 56: 3-2 - Motor kW-2

Range		Function
* 0	0–9999 kW	Sets the running power of the secondary motor in kW.

Table 57: 3-3 - Start Mode-2

Option		Function
		Selects the soft start mode.
*	Constant Current	
	Adaptive Control	

Table 58: 3-4 - Start Ramp Time-2

Range		Function
*10 s	0:01–3:00 (minutes:seconds)	Sets the total start time for an adaptive control start or the ramp time for current ramp starting (from the initial current to the current limit).

Table 59: 3-5 - Initial Current-2

Range		Function
*200%	100–600% FLC	Sets the initial start current level for current ramp starting as a percentage of motor full load current. Set so that the motor begins to accelerate immediately after a start is initiated. If current ramp starting is not required, set the initial current equal to the current limit.

Table 60: 3-6 - Current Limit-2

Range		Function
*350%	100–600% FLC	Sets the current limit for constant current and current ramp soft starting as a percentage of motor full load current.
NOTICE		
The VLT® Soft Starter MCD 600 applies the current limit on all soft starts, including adaptive control. If the current limit is too low or the start ramp time (<i>parameter 2-2 Start Ramp Time</i>) is too short, the motor may not start successfully.		

Table 61: 3-7 - Adaptive Start Profile-2

Option	Function
	Selects which profile the VLT® Soft Starter MCD 600 uses for an adaptive control soft start.
Early Acceleration	
* Constant Acceleration	
Late Acceleration	

Table 62: 3-8 - Kickstart Time-2

Range		Function
* 0000 ms	0–2000 ms	Sets the kickstart duration. A setting of 0 disables kickstart.

Table 63: 3-9 - Kickstart Level-2

Range		Function
*500%	100–700% FLC	Sets the level of the kickstart current.

Table 64: 3-10 - Jog Torque-2

Range		Function
*50%	20–100%	Sets the current limit for jog operation.

Table 65: 3-11 - Stop Mode-2

Option	Function
	Selects the stop mode.
Coast To Stop	
* TVR Soft Stop	
Adaptive Control	

Option		Function
	DC Brake	
	Soft Brake	

Table 66: 3-12 - Stop Time-2

Range		Function
*0 s	0:00–4:00 (minutes:seconds)	Sets the time for soft stopping the motor using TVR or adaptive control. If a main contactor is installed, the contactor must remain closed until the end of the stop time. Use the main contactor output (13, 14) to control the main contactor.

Table 67: 3-13 - Adaptive Stop Profile-2

Option		Function
		Selects which profile the soft starter uses for an adaptive control soft stop.
	Early Deceleration	
*	Constant Deceleration	
	Late Deceleration	

Table 68: 3-14 - Adaptive Control Gain-2

Range		Function
*75%	1–200%	Adjusts the performance of adaptive control. This setting affects both starting and stopping control.

Table 69: 3-15 - Multi Pump-2

Option		Function
		Adjusts the performance of adaptive control to suit installations with multiple pumps connected to a common outlet manifold.
*	Single Pump	
	Manifold Pump	

Table 70: 3-16 - Start Delay-2

Range		Function
*0 s	0:00–60:00 (minutes:seconds)	Sets a delay after the starter receives a start command before it starts the motor.

Table 71: 3-17 - DC Brake Torque-2

Range		Function
*20%	20–100%	Sets the amount of brake torque the soft starter uses to slow the motor.

Table 72: 3-18 - DC Brake Time-2

Range		Function
*1 s	0:01–0:30 (minutes:seconds)	Sets the duration for DC injection during a braking stop.

Table 73: 3-19 - Brake Current Limit-2

Range		Function
*250%	100–600% FLC	Sets the current limit for soft brake.

Table 74: 3-20 - Soft Brake Delay-2

Range		Function
*400 ms	400–2000 ms	Sets the time which the soft starter waits after a stop signal is received, before it begins to supply braking current to the motor. Set to allow time for K1 and K2 to switch.

10.8 Parameter Group 4-** Auto-Start/Stop

Table 75: 4-1 - Auto-Start/Stop Mode

Option		Function
		Enable or disable auto-start/stop operation.
*	Disable	
	Enable Clock Mode	
	Enable Timer Mode	

Table 76: 4-2 - Run Time

Range		Function
*00:00	00:00–23:59 hh:mm	Sets the duration for the soft starter to run after a timer mode auto-start.

Table 77: 4-3 - Stopped Time

Range		Function
*00:00	00:00–23:59 hh:mm	Sets the duration for the soft starter to remain stopped when operating in timer mode.

Table 78: 4-4 - Sunday Mode

Option		Function
		Enables or disables auto-start/stop for Sunday.
*	Start/Stop Disable	Disables auto-start/stop control. Any times scheduled in <i>parameter 4-5 Sunday Start Time</i> or <i>parameter 4-6 Sunday Stop Time</i> are ignored.
	Start Only Enable	Enables auto-start control. Any auto-stop times scheduled in <i>parameter 4-6 Sunday Stop Time</i> are ignored.
	Stop Only Enable	Enables auto-stop control. Any auto-start times scheduled in <i>parameter 4-5 Sunday Start Time</i> are ignored.
	Start/Stop Enable	Enables auto-start and auto-stop control.

Table 79: 4-5 - Sunday Start Time

Range		Function
*00:00	00:00–23:59	Sets the auto-start time for Sunday (24-hour format).

Table 80: 4-6 - Sunday Stop Time

Range		Function
*00:00	00:00–23:59	Sets the auto-stop time for Sunday (24-hour format).

Table 81: 4-7 - Monday Mode

Option		Function
		Enables or disables auto-start/stop for Monday.
*	Start/Stop Disable	
	Start Only Enable	
	Stop Only Enable	
	Start/Stop Enable	

Table 82: 4-8 - Monday Start Time

Range		Function
*00:00	00:00–23:59	Sets the auto-start time for Monday (24-hour format).

Table 83: 4-9 - Monday Stop Time

Range		Function
*00:00	00:00–23:59	Sets the auto-stop time for Monday (24-hour format).

Table 84: 4-10 - Tuesday Mode

Option		Function
		Enables or disables auto-start/stop for Tuesday.
*	Start/Stop Disable	
	Start Only Enable	
	Stop Only Enable	
	Start/Stop Enable	

Table 85: 4-11 - Tuesday Start Time

Range		Function
*00:00	00:00–23:59	Sets the auto-start time for Tuesday (24-hour format).

Table 86: 4-13 - Wednesday Mode

Option		Function
		Enables or disables auto-start/stop for Wednesday.
*	Start/Stop Disable	
	Start Only Enable	
	Stop Only Enable	
	Start/Stop Enable	

Table 87: 4-14 - Wednesday Start Time

Range		Function
*00:00	00:00–23:59	Sets the auto-start time for Wednesday (24-hour format).

Table 88: 4-15 - Wednesday Stop Time

Range		Function
*00:00	00:00–23:59	Sets the auto-stop time for Wednesday (24-hour format).

Table 89: 4-16 - Thursday Mode

Option		Function
		Enables or disables auto-start/stop for Thursday.
*	Start/Stop Disable	
	Start Only Enable	
	Stop Only Enable	
	Start/Stop Enable	

Table 90: 4-17 - Thursday Start Time

Range		Function
*00:00	00:00–23:59	Sets the auto-start time for Thursday (24-hour format).

Table 91: 4-18 - Thursday Stop Time

Range		Function
*00:00	00:00–23:59	Sets the auto-stop time for Thursday (24-hour format).

Table 92: 4-19 - Friday Mode

Option		Function
		Enables or disables auto-start/stop for Friday.
*	Start/Stop Disable	
	Start Only Enable	
	Stop Only Enable	
	Start/Stop Enable	

Table 93: 4-20 - Friday Start Time

Range		Function
*00:00	00:00–23:59	Sets the auto-start time for Friday (24-hour format).

Table 94: 4-21 - Friday Stop Time

Range		Function
*00:00	00:00–23:59	Sets the auto-stop time for Friday (24-hour format).

Table 95: 4-22 - Saturday Mode

Option		Function
		Enables or disables auto-start/stop for Saturday.
*	Start/Stop Disable	
	Start Only Enable	
	Stop Only Enable	
	Start/Stop Enable	

Table 96: 4-23 - Saturday Start Time

Range		Function
*00:00	00:00–23:59	Sets the auto-start time for Saturday (24-hour format).

Table 97: 4-24 - Saturday Stop Time

Range		Function
*00:00	00:00–23:59	Sets the auto-stop time for Saturday (24-hour format).

10.9 Parameter Group 5-** Protection Levels

Table 98: 5-1 - Current Imbalance

Range		Function
*30%	10–50%	Sets the trip point for current imbalance protection.

Table 99: 5-2 - Current Imbalance Delay

Range		Function
*3 s	0:00–4:00 (minutes:seconds)	Slows the soft starter's response to current imbalance, avoiding trips due to momentary fluctuations.

Table 100: 5-3 - Undercurrent

Range		Function
*20%	0–100%	Sets the trip point for undercurrent protection as a percentage of motor full load current. Set to a level between the motor's normal working range and the motor's magnetizing (no load) current (typically 25–35% of FLC). A setting of 0% disables undercurrent protection.

Table 101: 5-4 - Undercurrent Delay

Range		Function
* 5 s	00–4:00 (minutes:seconds)	Slows the soft starter's response to undercurrent, avoiding trips due to momentary fluctuations.

Table 102: 5-5 - Overcurrent

Range		Function
*400%	80–600%	Sets the trip point for overcurrent protection as a percentage of motor full load current.

Table 103: 5-6 - Overcurrent Delay

Range		Function
* 0 s	0:00–1:00 (minutes:seconds)	Slows the soft starter's response to overcurrent, avoiding trips due to momentary overcurrent events.

Table 104: 5-7 - Undervoltage

Range		Function
*350	100–1200 V	Sets the trip point for undervoltage protection. Set as required. <div style="text-align: center; border: 1px solid black; padding: 5px; margin-top: 10px;"> NOTICE Voltage protection does not operate correctly until the soft starter is in Run mode. </div>

Table 105: 5-8 - Undervoltage Delay

Range		Function
* 1 s	0:01–1:00 (minutes:seconds)	Slows the soft starter's response to undervoltage, avoiding trips due to momentary fluctuations.

Table 106: 5-9 - Overvoltage

Range		Function
*500	100–1500 V	Sets the trip point for overvoltage protection. Set as required.

Table 107: 5-10 - Overvoltage Delay

Range		Function
* 1 s	0:01–1:00 (minutes:seconds)	Slows the soft starter's response to overvoltage, avoiding trips due to momentary fluctuations.

Table 108: 5-11 - Underpower

Range		Function
*10%	10–120%	Sets the trip point for underpower protection. Set as required.

Table 109: 5-12 - Underpower Delay

Range		Function
*1 s	0:01–1:00 (minutes:seconds)	Slows the soft starter's response to underpower, avoiding trips due to momentary fluctuations.

Table 110: 5-13 - Overpower

Range		Function
*150%	80–200%	Sets the trip point for overpower protection. Set as required.

Table 111: 5-14 - Overpower Delay

Range		Function
* 1 s	0:01–1:00 (minutes:seconds)	Slows the soft starter's response to overpower, avoiding trips due to momentary fluctuations.

Table 112: 5-15 - Excess Start Time

Range		Function
*20 s	0:00–4:00 (minutes:seconds)	Excess start time is the maximum time the soft starter attempts to start the motor. If the motor does not transition to Run mode within the programmed limit, the soft starter trips. Set for a period slightly longer than required for a normal healthy start. A setting of 0 disables excess start time protection.

Table 113: 5-16- Restart Delay

Range		Function
*10 s	00:01–60:00 (minutes:seconds)	The soft starter can be configured to force a delay between the end of a stop and the beginning of the next start. During the restart delay period, the display shows the time remaining before another start can be attempted.

Table 114: 5-17 - Starts per Hour

Range	Function
*0 0–10	Sets the maximum number of starts the soft starter attempts in a 60-minute period. A setting of 0 disables this protection.

Table 115: 5-18 - Phase Sequence

Option	Function
	<p>Selects which phase sequences the soft starter allows at a start. During its pre-start checks, the soft starter examines the sequence of the phases at its input terminals and trips if the actual sequence does not match the selected option.</p> <div style="text-align: center; background-color: #cccccc; padding: 5px;">NOTICE</div> <p>When using DC brake, the mains supply must be connected to the soft starter (input terminals L1, L2, L3) in positive phase sequence. <i>Parameter 5-18 Phase Sequence</i> must be set to <i>Positive Only</i>.</p>
* Any Sequence	
Positive only	
Negative Only	

10.10 Parameter Group 6-** Protection Action

Table 116: 6-1 - Auto-Reset Count

Range	Function
*0 0–5	Sets how many times the soft starter auto-resets if it continues to trip. The reset counter increases by 1 each time the soft starter auto-resets, and resets after a successful start. Setting this parameter to 0 disables auto-reset.

Table 117: 6-2 - Auto-Reset Delay

Range	Function
*5 s 0:05–15:00 (minutes:seconds)	Sets a delay before the soft starter auto-resets a trip.

Table 118: 6-3 - Current Imbalance

Option	Function
	Selects the soft starter's response to each protection. All protection events are written to the event log.
* Soft Trip and Log	The soft starter stops the motor as selected in <i>parameter 2-9 Stop Mode</i> or <i>parameter 3-11 Stop Mode</i> , then enters trip state. The trip must be reset before the soft starter can restart.
Soft Trip and Reset	The soft starter stops the motor as selected in <i>parameter 2-9 Stop Mode</i> or <i>parameter 3-11 Stop Mode</i> , then enters trip state. The trip resets after the auto-reset delay.
Trip Starter	The soft starter removes power and the motor coasts to stop. The trip must be reset before the soft starter can restart.
Trip and Reset	The soft starter removes power and the motor coasts to stop. The trip resets after the auto-reset delay.
Warn and Log	The protection is written to the event log and the display shows a warning message, but the soft starter continues to operate.
Log Only	The protection is written to the event log but the soft starter continues to operate.
Trip+Shunt Relay	The soft starter removes power and the motor coasts to stop. The shunt trip relay (13, 14) activates and the circuit breaker disconnects mains voltage from the soft starter. The circuit breaker must be manually reset before operation can resume. This option is only effective if <i>parameter 20-8 Shunt Trip Mode</i> is set to <i>Enable</i> .

Table 119: 6-4 - Undercurrent

Option	Function
	Selects the soft starter's response to the protection event.
* Soft Trip and Log	
Soft Trip and Reset	
Trip Starter	
Trip and Reset	
Warn and Log	
Log Only	
Trip+Shunt Relay	

Table 120: 6-5 - Overcurrent

Option	Function
	Selects the soft starter's response to the protection event.
* Soft Trip and Log	
Soft Trip and Reset	
Trip Starter	
Trip and Reset	
Warn and Log	
Log Only	

Option	Function
Trip+Shunt Relay	

Table 121: 6-6 - Undervoltage

Option	Function
	Selects the soft starter's response to the protection event.
* Soft Trip and Log	
Soft Trip and Reset	
Trip Starter	
Trip and Reset	
Warn and Log	
Log Only	
Trip+Shunt Relay	

Table 122: 6-7 - Overvoltage

Option	Function
	Selects the soft starter's response to the protection event.
* Soft Trip and Log	
Soft Trip and Reset	
Trip Starter	
Trip and Reset	
Warn and Log	
Log Only	
Trip+Shunt Relay	

Table 123: 6-8 - Underpower

Option	Function
	Selects the soft starter's response to the protection event.
Soft Trip and Log	
Soft Trip and Reset	
Trip Starter	
Trip and Reset	
Warn and Log	
* Log Only	
Trip+Shunt Relay	

Table 124: 6-9 - Overpower

Option	Function
	Selects the soft starter's response to the protection event.
Soft Trip and Log	
Soft Trip and Reset	
Trip Starter	
Trip and Reset	
Warn and Log	
* Log Only	
Shunt+Trip Relay	

Table 125: 6-10 - Excess Start Time

Option	Function
	Selects the soft starter's response to the protection event.
* Soft Trip and Log	
Soft Trip and Reset	
Trip Starter	
Trip and Reset	
Warn and Log	
Log Only	
Trip+Shunt Relay	

Table 126: 6-11 - Input A Trip

Option	Function
	Selects the soft starter's response to the protection event.
* Soft Trip and Log	
Soft Trip and Reset	
Trip Starter	
Trip and Reset	
Warn and Log	
Log Only	
Trip+Shunt Relay	

Table 127: 6-12 - Input B Trip

Option	Function
	Selects the soft starter's response to the protection event.

Option		Function
*	Soft Trip and Log	
	Soft Trip and Reset	
	Trip Starter	
	Trip and Reset	
	Warn and Log	
	Log Only	
	Trip+Shunt Relay	

Table 128: 6-13 - Network Communications

Option		Function
		Selects the soft starter's response to the protection event.
*	Soft Trip and Log	
	Soft Trip and Reset	
	Trip Starter	
	Trip and Reset	
	Warn and Log	
	Log Only	
	Stop	The soft starter performs a soft stop and can then restart without a reset.
	Trip+Shunt Relay	

Table 129: 6-14 - Remote Keypad Fault

Option		Function
		Selects the soft starter's response to the protection event.
*	Soft Trip and Log	
	Soft Trip and Reset	
	Trip Starter	
	Trip and Reset	
	Warn and Log	
	Log Only	
	Trip+Shunt Relay	

Table 130: 6-15 - Frequency

Option		Function
		Selects the soft starter's response to the protection event.
*	Soft Trip and Log	

Option	Function
	Soft Trip and Reset
	Trip Starter
	Trip and Reset
	Warn and Log
	Log Only
	Trip+Shunt Relay

Table 131: 6-16 - Phase Sequence

Option	Function
	Selects the soft starter's response to the protection event.
*	Soft Trip and Log
	Soft Trip and Reset
	Trip Starter
	Trip and Reset
	Warn and Log
	Log Only
	Trip+Shunt Relay

Table 132: 6-17 - Motor Overtemperature

Option	Function
	Selects the soft starter's response to the protection event.
*	Soft Trip and Log
	Soft Trip and Reset
	Trip Starter
	Trip and Reset
	Warn and Log
	Log Only
	Trip+Shunt Relay

Table 133: 6-18 - Motor Thermistor Circuit

Option	Function
	Selects the soft starter's response to the protection event.
*	Soft Trip and Log
	Soft Trip and Reset
	Trip Starter

Option	Function
Trip and Reset	
Warn and Log	
Log Only	
Trip+Shunt Relay	

Table 134: 6-19 - Shorted SCR Action

Option	Function
	Selects whether the soft starter allows PowerThrough operation, if the soft starter is damaged on 1 phase. The soft starter uses 2-phase control, allowing the motor to continue operating in critical applications.
* 3-phase Control Only	
PowerThrough	
Trip+Shunt Relay	

For more details on PowerThrough operation, see [9.4 PowerThrough](#).

Table 135: 6-20 - Battery/Clock

Option	Function
	Selects the soft starter's response to the protection event.
* Soft Trip and Log	
Soft Trip and Reset	
Trip Starter	
Trip and Reset	
Warn and Log	
Log Only	
Trip+Shunt Relay	

10.11 Parameter Group 7-** Inputs

Table 136: 7-1 - Input A Function

Option	Function
	Selects the function of Input A.
Command Override: Network	Overrides the setting of <i>parameter 1-1 Command Source</i> and sets the command source to the communications network.
Command Override: Digital	Overrides the setting of <i>parameter 1-1 Command Source</i> and sets the command source to the digital inputs.
Command Override: Keypad	Overrides the setting of <i>parameter 1-1 Command Source</i> and sets the command source to the remote LCP.
* Input Trip (N/O)	A closed circuit across DI-A, COM+ trips the soft starter.
Input Trip (N/C)	An open circuit across DI-A, COM+ trips the soft starter.

Option	Function
Emergency Mode	A closed circuit across DI-A, COM+ activates emergency mode. When the soft starter receives a start command, it continues to run until a stop command is received, ignoring all trips and warnings.
Jog Forward	Activates jog operation in forward direction.
Jog Reverse	Activates jog operation in reverse direction.
Zero Speed Sensor	An open circuit across DI-A, COM+ indicates to the soft starter that the motor has reached a standstill. The soft starter requires a normally open zero-speed sensor.
Motor Set Select	A closed circuit across DI-A, COM+ instructs the soft starter to use the secondary motor configuration for the next start/stop cycle.
Reverse Direction	A closed circuit across DI-A, COM+ instructs the soft starter to reverse the phase sequence for the next start.
Pump Clean	Activates the pump clean function.

Table 137: 7-2 - Input A Trip

Option	Function
	Selects when an input trip can occur.
Always Active	A trip can occur at any time when the soft starter is receiving power.
* Operating Only	A trip can occur while the soft starter is running, stopping, or starting.
Run Only	A trip can only occur while the soft starter is running.

Table 138: 7-3 - Input A Trip Delay

Range	Function
*0 s 0:00–4:00 (minutes:seconds)	Sets a delay between the input activating and the soft starter tripping.

Table 139: 7-4 - Input A Initial Delay

Range	Function
* 0 s 00:00–30:00 (minutes:seconds)	Sets a delay before an input trip can occur. The initial delay is counted from the time a start signal is received. The state of the input is ignored until the initial delay has elapsed.

Table 140: 7-5 - Input B Function

Option	Function
	Selects the function of Input B. See <i>parameter 7-1 Input A Function</i> for details.
* Input Trip (N/O)	
Input Trip (N/C)	
Emergency Mode	
Jog Forward	
Jog Reverse	
Zero Speed Sensor	

Option	Function
Motor Set Select	
Reverse Direction	
Pump Clean	

Table 141: 7-6 - Input B Trip

Option	Function
	Selects when an input trip can occur.
Always Active	
* Operating Only	
Run Only	

Table 142: 7-7 - Input B Trip Delay

Range	Function
* 0 s 0:00–4:00 (minutes:seconds)	Sets a delay between the input activating and the soft starter tripping.

Table 143: 7-8 - Input B Initial Delay

Range	Function
* 0 s 00:00–30:00 (minutes:seconds)	<p>Sets a delay before an input trip can occur.</p> <p>The initial delay is counted from the time a start signal is received.</p> <p>The state of the input is ignored until the initial delay has elapsed.</p>

Table 144: 7-9 - Reset/Enable Logic

Option	Function
	Selects whether the reset input (RESET, COM+) is normally open or normally closed.
* Normally Closed	
Normally Open	<div style="text-align: center; background-color: #cccccc; padding: 5px;">NOTICE</div> <p>If the reset input is active, the soft starter does not operate.</p>

Table 145: 7-10 - Input A Name

Option	Function
	<p>Selects a message for the LCP to show when Input A is active.</p> <p>The custom message can be loaded via the USB port.</p>
* Input A Trip	
Low Pressure	
High Pressure	
Pump Fault	

Option	Function
Low Level	
High Level	
No Flow	
Starter Disable	
Controller	
PLC	
Vibration Alarm	
Field Trip	
Interlock Trip	
Motor Temp	
Motor Prot	
Feeder Prot	
Custom Message	

Table 146: 7-11 - Input B Name

Option	Function
	Selects a message for the LCP to show when Input B is active.
* Input B Trip	
Low Pressure	
High Pressure	
Pump Fault	
Low Level	
High Level	
No Flow	
Starter Disable	
Controller	
PLC	
Vibration Alarm	
Field Trip	
Interlock Trip	
Motor Temp	
Motor Prot	
Feeder Prot	

Option	Function
Custom Message	

10.12 Parameter Group 8-** Relay Outputs

Table 147: 8-1 - Relay A Function

Option	Function
	Selects the function of Relay A. Relay A is a changeover relay.
Off	Relay A is not used.
Ready	The relay is closed when the soft starter is in Ready state.
* Run	The Run output closes when the soft start is complete (when the starting current drops below 120% of the programmed motor full load current). The output remains closed until the beginning of a stop (either soft stop or coast to stop).
Warning	The relay closes when the soft starter issues a warning.
Trip	The relay closes when the starter trips.
Low Current Flag	The relay closes when the low current flag activates while the motor is running (see <i>parameter 8-7 Low Current Flag</i>).
High Current Flag	The relay closes when the high current flag activates while the motor is running (see <i>parameter 8-8 High Current Flag</i>).
Motor Temperature Flag	The relay closes when the motor temperature flag activates (see <i>parameter 8-9 Motor Temperature Flag</i>).
Soft Brake Relay	The relay closes when the soft starter receives a stop signal, and remains closed until the end of soft brake.
Reversing Contactor	The relay controls an external contactor, for reverse operation.
Trip Failsafe	The relay closes when control power is applied. The relay opens if the soft starter trips or if control power is lost.

Table 148: 8-2 - Relay A On Delay

Range	Function
* 0 s 0:00–5:00 (minutes:seconds)	Sets the delay for changing the state of Relay A.

Table 149: 8-3 - Relay A Off Delay

Range	Function
* 0 s 0:00–5:00 (minutes:seconds)	Sets the delay for changing the state of Relay A.

Table 150: 8-4 - Relay B Function

Option	Function
	Selects the function of Relay B (normally open). See <i>parameter 8-1 Relay A Function</i> for details.
Off	

Option	Function
Ready	
* Run	
Warning	
Trip	
Low Current Flag	
High Current Flag	
Motor Temperature Flag	
Soft Brake Relay	
Reversing Contactor	
Trip Failsafe	

Table 151: 8-5 - Relay B On Delay

Range	Function
* 0 s	0:00–5:00 (minutes:seconds) Sets the delay for closing Relay B.

Table 152: 8-6 - Relay B Off Delay

Range	Function
* 0 s	0:00–5:00 (minutes:seconds) Sets the delay for reopening Relay B.

Table 153: 8-7 - Low Current Flag

Range	Function
* 50%	1–100% FLC The soft starter has low and high current flags to give early warning of abnormal operation. The current flags can be configured to indicate an abnormal current level during operation, between the normal operating level and the undercurrent or instantaneous overcurrent trip levels. The flags can signal the situation to external equipment via 1 of the programmable outputs. The flags clear when the current returns within the normal operating range by 10% of the programmed flag value. Set the level at which the low current flag operates as a percentage of motor full load current.

Table 154: 8-8 - High Current Flag

Range	Function
* 100%	50–600% FLC Sets the level at which the high current flag operates as a percentage of motor full load current.

Table 155: 8-9 - Motor Temperature Flag

Range	Function
* 80%	0–160% The soft starter has a motor temperature flag to give early warning of abnormal operation. The flag can indicate that the motor is operating above its normal operating temperature but lower than the overload limit. The flag can signal the situation to external equipment via 1 of the programmable outputs. Set the level at which the motor temperature flag operates as a percentage of the motor's thermal capacity.

Table 156: 8-10 - Main Contactor Time

Range		Function
*400 ms	100–2000 ms	Sets the delay period between the soft starter switching the main contactor output (terminals 13, 14) and beginning the pre-start checks (before a start), or entering the not-ready state (after a stop). Set according to the specifications of the main contactor used.

10.13 Parameter Group 9-** Analog Output

Table 157: 9-1 - Analog Output A

Option	Function
	Selects the information reported via the analog output.
* Current (% FLC)	Current as a percentage of motor full load current.
Motor Temp (%)	The motor's temperature, calculated by the thermal model.
Motor pf	Motor power factor, measured by the soft starter.
Motor Power (%kW)	Motor power, as a percentage of the programmed power.
Heat Sink Temperature (%)	The soft starter temperature as a percentage of the maximum allowed operating temperature of the heat sink.

Table 158: 9-2 - Analog A Scale

Range		Function
		Selects the range of the analog output.
	0–20 mA	
*	4–20 mA	

Table 159: 9-3 - Analog A Maximum Adjustment

Range		Function
* 100%	0–600%	Calibrates the upper limit of the analog output to match the signal measured on an external current measuring device.

Table 160: 9-4 - Analog A Minimum Adjustment

Range		Function
* 0%	0–600%	Calibrates the lower limit of the analog output to match the signal measured on an external current measuring device.

10.14 Parameter Group 10-** Display

Table 161: 10-1 - Language

Option	Function
	Selects in which language the LCP shows messages and feedback.
* English	
Chinese	
Español	
Deutsch	

Option		Function
	Português	
	Français	
	Italiano	
	Russian	

Table 162: 10-2 - Temperature Scale

Option		Function
		Selects whether the soft starter shows temperatures in degrees Celsius or Fahrenheit.
*	Celsius	
	Fahrenheit	

Table 163: 10-3 - Graph Timebase

Option		Function
		Sets the graph time scale. The graph replaces the old data with new data progressively.
*	30 seconds	
	1 minute	
	30 minutes	
	1 hour	

Table 164: 10-4 - Graph Maximum Adjustment

Range		Function
* 400%	0–600%	Adjusts the upper limit of the performance graph.

Table 165: 10-5 - Graph Minimum Adjustment

Range		Function
*0%	0–600%	Adjusts the lower limit of the performance graph.

Table 166: 10-6 - Current Calibration

Range		Function
*100%	85–115%	Calibrates the soft starter's current monitoring circuits to match an external current metering device. Use the following formula to determine the necessary adjustment: $\text{Calibration (\%)} = \frac{\text{Current shown on soft starter display}}{\text{Current measured by external device}}$

Table 167: 10-7 - Adjustment Lock

Option		Function
		Selects whether the LCP allows parameters to be changed via the Main Menu.
*	Read & Write	Allows altering of parameter values in the Main Menu.

Option	Function
Read Only	Prevents users altering parameter values in the Main Menu. Parameter values can still be viewed.

Table 168: 10-8 - User Parameter 1

Option	Function
	Selects which information is shown on the main monitoring screen.
Blank	Shows no data in the selected area, allowing long messages to be shown without overlapping.
* Current	Average rms current across all 3 phases.
Motor Voltage	Average rms voltage across all 3 phases.
P1 Voltage	Phase 1 voltage.
P2 Voltage	Phase 2 voltage.
P3 Voltage	Phase 3 voltage.
Mains Frequency	The average frequency measured on 3 phases.
Motor pf	The motor's power factor, measured by the soft starter.
Motor Power	The motor's running power in kW.
Motor Temp (%)	The motor's temperature, calculated by the thermal model.
Hours Run	The number of hours the motor has run via the soft starter.
Number of Starts	The number of starts the soft starter has completed since the start counter was last reset.
Pump Pressure	The pressure at the pump, as configured in <i>parameters 30-2 to 30-4</i> . This information is only available if the smart card is installed.
Pump Flow	The flow at the pump, as configured in <i>parameters 30-6 to 30-11</i> . This information is only available if the smart card is installed.
Well Depth	The depth of the well, as configured in <i>parameters 30-13 to 30-15</i> . This information is only available if the smart card is installed.
Pump Temperature	The pump temperature, as measured by the PT100. This information is only available if the smart card is installed.
Analog Output Value	The value of the analog output (see <i>parameter group 9-** Analog Output</i>).
Heat Sink Temperature	The soft starter's temperature measured at the heat sink.
Bypass Model (%)	The percentage of thermal capacity remaining in the bypass contactor.
SCR Temperature	The temperature of the SCRs calculated by the thermal model.
Rating Capacity (%)	The thermal capacity available in the soft starter for its next start.

Table 169: 10-9 - User Parameter 2

Option	Function
	Selects which information is shown on the main monitoring screen. See <i>parameter 10-8 User Parameter 1</i> for details.

Option		Function
*	Motor Voltage	See <i>parameter 10-8 User Parameter 1</i> for details.

Table 170: 10-10 - User Parameter 3

Option		Function
		Selects which information is shown on the programmable monitoring screen.
	Blank	See <i>parameter 10-8 User Parameter 1</i> for details.
	Current	See <i>parameter 10-8 User Parameter 1</i> for details.
	Motor Voltage	See <i>parameter 10-8 User Parameter 1</i> for details.
	P1 Voltage	See <i>parameter 10-8 User Parameter 1</i> for details.
	P2 Voltage	See <i>parameter 10-8 User Parameter 1</i> for details.
	P3 Voltage	See <i>parameter 10-8 User Parameter 1</i> for details.
*	Mains Frequency	See <i>parameter 10-8 User Parameter 1</i> for details.
	Motor pf	See <i>parameter 10-8 User Parameter 1</i> for details.
	Motor Power	See <i>parameter 10-8 User Parameter 1</i> for details.
	Motor Temperature (%)	See <i>parameter 10-8 User Parameter 1</i> for details.
	Hours Run	See <i>parameter 10-8 User Parameter 1</i> for details.
	Number of Starts	See <i>parameter 10-8 User Parameter 1</i> for details.
	Pump Pressure	See <i>parameter 10-8 User Parameter 1</i> for details.
	Pump Flow	See <i>parameter 10-8 User Parameter 1</i> for details.
	Well Depth	See <i>parameter 10-8 User Parameter 1</i> for details.
	Pump Temperature	See <i>parameter 10-8 User Parameter 1</i> for details.
	Analog Output Value	See <i>parameter 10-8 User Parameter 1</i> for details.
	Heat Sink Temperature	See <i>parameter 10-8 User Parameter 1</i> for details.
	Bypass Model (%)	See <i>parameter 10-8 User Parameter 1</i> for details.
	SCR Temperature	See <i>parameter 10-8 User Parameter 1</i> for details.
	Rating Capacity (%)	See <i>parameter 10-8 User Parameter 1</i> for details.
	Ground Current	

Table 171: 10-11 - User Parameter 4

Option		Function
		Selects which information is shown on the programmable monitoring screen. See <i>parameter 10-10 User Parameter 3</i> for details.
*	Motor pf	See <i>parameter 10-10 User Parameter 3</i> for details.

Table 172: 10-12 - User Parameter 5

Option		Function
		Selects which information is shown on the programmable monitoring screen. See parameter 10-10 User Parameter 3 for details.
*	Motor Power	See parameter 10-10 User Parameter 3 for details.

Table 173: 10-13 - User Parameter 6

Option		Function
		Selects which information is shown on the programmable monitoring screen. See parameter 10-10 User Parameter 3 for details.
*	Motor Temp (%)	See parameter 10-10 User Parameter 3 for details.

10.15 Parameter Group 11-** Pump Clean

Table 174: 11-1 - Reverse Torque

Range		Function
* 20%	20–100%	Sets the torque level for reverse jog operation during pump clean.

Table 175: 11-2 - Reverse Time

Range		Function
* 10 s	0:00–1:00 (minutes:seconds)	Sets the time for the starter to operate in reverse jog during a pump clean cycle.

Table 176: 11-3 - Forward Current Limit

Range		Function
*100%	100–600% FLC	Sets the current limit for forward start operation during pump clean.

Table 177: 11-4 - Forward Time

Range		Function
* 10 s	0:00–1:00 (minutes:seconds)	Sets the time for the soft starter to run the motor after a forward start during a pump clean cycle.

Table 178: 11-5 - Pump Stop Mode

Option		Function
		Selects the stop mode for pump clean.
*	Coast To Stop	
	TVR Soft Stop	

Table 179: 11-6 - Pump Stop Time

Range		Function
* 10 s	0:00–1:00 (minutes:seconds)	Sets the stopping time for the starter during a pump clean cycle.

Table 180: 11-7 - Pump Clean Cycles

Range		Function
* 1	1–5	Sets how many times the soft starter repeats the pump clean cycle.

10.16 Parameter Group 12-** Communication Card

Table 181: 12-1 - Modbus Address

Range		Function
* 1	1–254	Sets the Modbus RTU network address for the soft starter.

Table 182: 12-2 - Modbus Baud Rate

Option	Function
	Selects the baud rate for Modbus RTU communications.
	4800
*	9600
	19200
	38400

Table 183: 12-3 - Modbus Parity

Option	Function
	Selects the parity for Modbus RTU communications.
*	None
	Odd
	Even
	10-bit

Table 184: 12-4 - Modbus Timeout

Option	Function
	Selects the timeout for Modbus RTU communications.
*	Off
	10 seconds
	60 seconds
	100 seconds

Table 185: 12-5 - Devicenet Address

Range		Function
*0	0–63	Sets the DeviceNet network address for the soft starter.

Table 186: 12-6 - Devicenet Baud Rate

Option		Function
		Selects the baud rate for DeviceNet communications.
*	125 kB	
	250 kB	
	500 kB	

Table 187: 12-7 - PROFIBUS Address

Range		Function
*1	1–125	Sets the PROFIBUS network address for the soft starter.

Table 188: 12-8 - Gateway Address

Range		Function
*192	0–255	Sets the 1 st component of the network gateway address. The gateway address is set using <i>parameters 12-8 to 12-11</i> and the default address is 192.168.0.100.

Table 189: 12-9 - Gateway Address 2

Range		Function
*168	0–255	Sets the 2 nd component of the network gateway address.

Table 190: 12-10 - Gateway Address 3

Range		Function
*0	0–255	Sets the 3 rd component of the network gateway address.

Table 191: 12-11 - Gateway Address 4

Range		Function
*100	0–255	Sets the 4 th component of the network gateway address.
<div style="background-color: #cccccc; padding: 5px; margin: 10px auto; width: 80%;"> <p style="margin: 0;">NOTICE</p> <p style="margin: 0;">The network address can also be set via the Network Address options in <i>Set-up Tools</i>.</p> </div>		

Table 192: 12-12 - IP Address

Range		Function
*192	0–255	Sets the 1 st component of the soft starter's IP address for Ethernet communications. The IP address is set using <i>parameter 12-12 to 12-15</i> and the default address is 192.168.0.2.

Table 193: 12-13 - IP Address 2

Range		Function
*168	0–255	Sets the 2 nd component of the soft starter's IP address for Ethernet communications.

Table 194: 12-14 - IP Address 3

Range		Function
*0	0–255	Sets the 3 rd component of the soft starter's IP address for Ethernet communications.

Table 195: 12-15 - IP Address 4

Range		Function
*2	0–255	Sets the 4 th component of the soft starter's IP address for Ethernet communications.
NOTICE		
The network address can also be set via the Network Address options in the <i>Set-up Tools</i> .		

Table 196: 12-16 - Subnet Mask

Range		Function
*255	0–255	Sets the 1 st component of the network subnet mask for Ethernet communications. The subnet mask is set using <i>parameters 12-16 to 12-19</i> and the default mask is 255.255.255.0.

Table 197: 12-17 - Subnet Mask 2

Range		Function
*255	0–255	Sets the 2 nd component of the network subnet mask for Ethernet communications.

Table 198: 12-18 - Subnet Mask 3

Range		Function
*255	0–255	Sets the 3 rd component of the network subnet mask for Ethernet communications.

Table 199: 12-19 - Subnet Mask 4

Range		Function
*0	0–255	Sets the 4 th component of the network subnet mask for Ethernet communications.
NOTICE		
The network address can also be set via the Network Address options in the <i>Set-up Tools</i> .		

Table 200: 12-20 - DHCP

Option	Function
	Selects whether the communications card accepts an IP address assigned by DHCP.
* Disable	
Enable	
NOTICE	
DHCP addressing is available with Modbus TCP and EtherNet/IP. DHCP addressing is not supported with PROFINET.	

Table 201: 12-21 - Location ID

Range		Function
*0	0–65535	Sets the soft starter's unique location ID.

10.17 Parameter Group 20-** Advanced

Table 202: 20-1 - Tracking Gain

Range		Function
*50%	1–200%	Fine-tunes the behavior of the adaptive control algorithm.

Table 203: 20-2 - Pedestal Detect

Range		Function
* 80%	0–200%	Adjusts the behavior of the adaptive control algorithm for soft stop.

Table 204: 20-3 - Bypass Contactor Delay

Range		Function
*100 ms	50–200 ms	Sets the soft starter to match the bypass contactor closing/opening time. Set according to the specifications of the bypass contactor used. If this time is too short, the soft starter will trip.

Table 205: 20-4 - Model Rating

Range		Function
*Model dependent	Model dependent	<p>The soft starter’s internal model reference, as shown on the silver label on the side of the unit. This parameter is a read-only parameter. If the software is to be upgraded (SW version 3.0 and after), as part of applying the upgrade firmware update, the MCD 600 requests the M/R code to be entered. This code is printed on the product serial label as shown [1] below. This is only required to be entered once as part of the update process. When entered, the parameter switches back to read-only. If a wrong value by mistake has been entered, this can re-activate the field by pressing [^]/[v] and cycling the control power. Once the code is re-entered, it will again become read-only.</p>  <p style="text-align: right; margin-right: 10px;">e77ha725.10</p>
		NOTICE
		This parameter can only be adjusted by authorized servicing agents.

Table 206: 20-5 - Screen Timeout

Option		Function
		Sets the timeout for the menu to close automatically if no LCP activity is detected.
*	1 minute	
	2 minutes	

Option	Function
3 minutes	
4 minutes	
5 minutes	

Table 207: 20-6 - Motor Connection

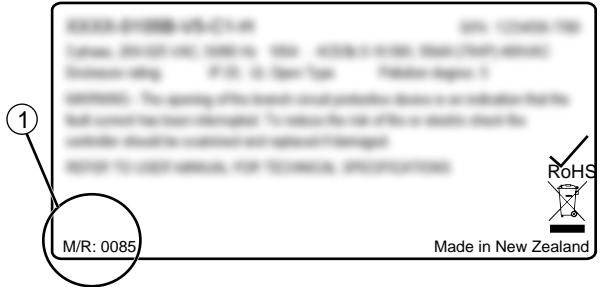
Option	Function
	Selects whether the soft starter automatically detects the format of the connection to the motor.
* Auto-detect	
In-line	
Inside delta	

Table 208: 20-8 - Shunt Trip Mode

Option	Function
	If a non-bypassed soft starter is installed with an external bypass contactor, the current rating of the soft starter changes. Enabling this parameter increases the maximum current rating and adjusts the thermal model of the soft starter.
* Disable	
Enable	

N O T I C E

Parameter 20-7 External Bypass only applies to models MCD6-0590C – MCD6-1134C. Changing the settings of this parameter has no effect on other models.

Table 209: 20-7 - External Bypass

Option	Function
	Reconfigures the main contactor output (13, 14) of the soft starter for use as a shunt trip relay. When the soft starter trips on selected conditions, the relay activates and the shunt trip triggers the circuit breaker and disconnects mains voltage from the soft starter. Use <i>parameters 6-3 to 6-20</i> to select which trips will activate the shunt trip relay.
* Disable	
Enable	

N O T I C E

If shunt trip operation is enabled, the shunt trip relay activates for certain non-adjustable trips as well as the selected adjustable trips.

- Current at Stop
- Current Read Err Lx
- EEPROM Fail
- Firing Fail Px
- Instantaneous Overcurrent
- Internal Fault

- Motor Connection
- SCR Itsm
- VZC Fail Px

10.18 Parameter Groups 30-** to 36-**

Parameter groups 30-** to 36-** are only visible if a Smart Card is installed and is supported by the soft starter. For parameter details, refer to the Pump Smart Card Installation Guide.

10.19 Parameter Group 40-** Ground Fault

N O T I C E

Ground fault protection is only available if a compatible expansion card is installed.

Table 210: 40-1 - Ground Fault Level

Range		Function
*0 A	0–50 A	Sets the trip point for ground fault protection. A setting of 0 disables this protection.

Table 211: 40-2 - Ground Fault Delay

Range		Function
*1 s	00:00–01:30 mm:ss	Slows the soft starter's response to ground fault variation, avoiding trips due to momentary fluctuations. If the soft starter detects ground currents above 50 A, it ignores the delay setting and trips within 1 s.

Table 212: 40-3 - Ground Fault Trip Active

Option	Function
	Selects when a ground fault trip can occur.
Always Active	A trip can occur at any time when the soft starter is receiving power.
* Operating Only	A trip can occur while the soft starter is running, stopping, or starting.
Run Only	A trip can only occur while the soft starter is running.

Table 213: 40-4 - Ground Fault Action

Option	Function
	Selects the soft starter's response to the protection event.
* Soft Trip and Log	
Soft Trip and Reset	
Trip Starter	
Trip and Reset	
Warn and Log	
Log Only	
Trip+Shunt Relay	

Table 214: 40-5 - Ground Fault CT Ratio

Option	Function
	Set to match the ratio of the ground current measuring CT.

Option		Function
*	1000:1	
	2000:1	

11 Troubleshooting

11.1 Protection Responses

When a protection condition is detected, the soft starter writes this to the event log and may also trip or issue a warning. The soft starter's response depends on the settings in *parameter group 6-** Protection Action*.

Some protection responses cannot be adjusted by the user. These trips are usually caused by external events (such as phase loss) or by a fault within the soft starter. These trips do not have associated parameters and cannot be set to *Warn* or *Log*.

If the soft starter trips, identify and clear the condition that triggered the trip, then reset the soft starter before restarting. To reset the soft starter, press [Back] on the LCP or activate the reset remote input.

If the soft starter has issued a warning, it resets itself once the cause of the warning has been resolved.

11.2 Trip Messages

11.2.1 2-Phase-damaged SCR

Cause

This message is shown if the soft starter has tripped on *Lx-Tx shorted* during the prestart checks and PowerThrough is enabled. It indicates that the soft starter now operates in PowerThrough mode (2-phase control only).

Troubleshooting

- Check for either a shorted SCR or a short within the bypass contactor.
- Check also *parameter 6-19 Shorted SCR Action*.

11.2.2 Battery/Clock

Cause

A verification error has occurred on the real-time clock, or the back-up battery voltage is low. If the battery is low and the power is off, date/time settings are lost.

Troubleshooting

- Reprogram the date and time.
- The battery is not removable. To replace the battery, the main control PCB must be replaced.
- Check also *parameter 6-20 Battery Clock*.

11.2.3 Bypass Overload

Cause

This trip is not adjustable. Bypass overload protection protects the soft starter from severe operating overloads while running. The soft starter trips if it detects overcurrent at 600% of the contactor rating. Related parameters: None.

Troubleshooting

There are no parameters related to this trip message.

11.2.4 Current at Stop

Cause

The soft starter has detected current at a time when no current is expected (ready, not ready, or tripped states).

Troubleshooting

- If the motor is connected inside delta (6-wire connection) and no main contactor is installed, a short-circuited SCR may be passing current to the motor.
- There are no parameters related to this trip message.

11.2.5 Current Imbalance

Cause

Problems with the motor, the environment, or the installation can cause current imbalance, such as:

- An imbalance in the incoming mains voltage.
- A problem with the motor windings.
- A light load on the motor.

- A phase loss on mains terminals L1, L2, or L3 during Run mode.
- An SCR that has failed open circuit. A failed SCR can only be diagnosed accurately by replacing the SCR and checking the soft starter performance.

Troubleshooting

- Check the following parameters:
 - *Parameter 5-1 Current Imbalance.*
 - *Parameter 5-2 Current Imbalance Delay.*
 - *Parameter 6-3 Current Imbalance.*

11.2.6 Current Read Err Lx (Where X is 1, 2, or 3)

Cause

Internal fault (PCB fault). The output from the current transformer circuit is not close enough to 0 when the SCRs are turned off.

Troubleshooting

- Contact the local Danfoss supplier for advice.
- There are no related parameters to this trip message.

11.2.7 Depth Sensor

Cause

The smart card has detected a fault with the depth sensor.

Troubleshooting

- Check the following parameters:
 - *Parameter 30-12 Depth Sensor Type.*
 - *Parameter 36-3 Depth Sensor.*

11.2.8 EEPROM Fail

Cause

An error occurred loading data from the EEPROM to RAM when the LCP powered up.

Troubleshooting

- If the problem persists, contact the local distributor.
- There are no parameters related to this trip message.

11.2.9 Excess Start Time

Cause

Excess start time trip can occur under the following conditions:

- *Parameter 1-2 Motor Full Load Current* is not appropriate for the motor.
- *Parameter 2-4 Current Limit* has been set too low.
- *Parameter 2-2 Start Ramp Time* has been set greater than the setting for *parameter 5-15 Excess Start Time*.
- *Parameter 2-2 Start Ramp Time* is set too short for a high inertia load when using adaptive control.

Troubleshooting

- *Parameter 1-2 Motor Full Load Current.*
- *Parameter 2-2 Start Ramp Time.*
- *Parameter 2-4 Current Limit.*
- *Parameter 3-4 Start Ramp Time-2.*
- *Parameter 3-6 Current Limit-2.*

11.2.10 Firing Fail Px (Where X is phase 1, 2, or 3)

Cause

The SCR did not fire as expected.

Troubleshooting

- Check for faulty SCRs and internal wiring faults.
- There are no parameters related to this trip message.

11.2.11 FLC Too High

The soft starter can be used on a motor with a higher full load current (FLC) if it is connected inside delta, or if a non-bypassed soft starter is installed with an external bypass contactor.

Cause

If the soft starter is connected to the motor using inside delta configuration, the soft starter may not be detecting the connection correctly.

If the soft starter is a non-bypassed model and was previously used with an external bypass contactor and *parameter 20-7 External Bypass* has now been set to *Disable*, the FLC may be above the maximum non-bypassed rating.

Troubleshooting

- Set *parameter 20-6 Motor Connection* to the connection used for the motor (in-line or inside delta). If the failure remains, contact the local supplier for advice.
- Check that the non-bypassed rating of the soft starter is suitable for the motor, then set *parameter 1-2 Motor Full Load Current* to match the motor FLC.
- Check also the following parameters:
 - *Parameter 1-2 Motor Full Load Current.*
 - *Parameter 20-6 Motor Connection.*
 - *Parameter 20-7 External Bypass.*

11.2.12 Flow Sensor

Cause

The smart card has detected a fault with the flow sensor.

Troubleshooting

- Check the following parameters:
 - *Parameter 30-5 Flow Sensor Type.*
 - *Parameter 36-2 Flow Sensor.*

11.2.13 Flow Switch

Cause

The flow switch sensor (smart card terminals C23, C24) has closed.

Troubleshooting

- Check the following parameters:
 - *Parameter 30-5 Flow Sensor Type.*
 - *Parameter 36-8 Flow Switch.*

11.2.14 Frequency

Cause

This trip is not adjustable. The mains frequency is outside of the specified range. Check for other equipment in the area that could be affecting the mains supply, particularly drives and switch mode power supplies (SMPS). If the soft starter is connected to a generator-set supply, the generator may be too small or could have a speed control problem.

Troubleshooting

- Check *parameter 6-15 Frequency.*

11.2.15 Ground Fault

Troubleshooting

- Test the insulation of the output cables and the motor.
- Identify and resolve the cause of any ground fault.
- Check also the following parameters:

- *Parameter 40-1.*
- *Parameter 40-2.*
- *Parameter 40-3.*
- *Parameter 40-4.*
- *Parameter 40-5.*

11.2.16 Heat Sink Overtemperature

Troubleshooting

- Check that bypass contactors are operating.
- Check that cooling fans are operating (if fitted).
- If mounted in an enclosure, check if ventilation is adequate.
- Mount the VLT® Soft Starter MCD 600 vertically.
- There are no parameters related to this trip message.
- Check that the internal bypass contactors are operating. Use the run simulation to operate the soft starter and measure resistance across each controlled phase. Resistance should be $>0.2\text{ M}\Omega$ when the bypass contactor is open and $<0.2\ \Omega$ when the bypass contactor is closed.
- Measure the voltage across 1/L1-2/T1, 3/L2-4/T2, 5/L3-6/T3 while the soft starter is running. If the bypass contactor has closed, the voltage should be $\leq 0.5\text{ V AC}$. If the bypass contactor does not close, the voltage should be approximately 2 V AC .
- Check that the cooling fans are operating (models MCD6-0042B~MCD6-0579B).

11.2.17 High Flow

Cause

The flow sensor connected to the smart card has activated high-flow protection.

Troubleshooting

- Check the following parameters:
 - *Parameter 30-5 Flow Sensor Type.*
 - *Parameter 30-7 Flow at 4 mA.*
 - *Parameter 30-8 Flow at 20 mA.*
 - *Parameter 31-1 High Flow Trip Level.*
 - *Parameter 31-3 Flow Start Delay.*
 - *Parameter 31-4 Flow Response Delay.*
 - *Parameter 36-6 High Flow.*

11.2.18 High Pressure

Cause

The pressure sensor connected to the smart card has activated high-pressure protection.

Troubleshooting

- Check the following parameters:
 - *Parameter 30-1 Pressure Sensor Type.*
 - *Parameter 30-3 Pressure at 4 mA.*
 - *Parameter 30-4 Pressure at 20 mA.*
 - *Parameter 32-1 High Pressure Trip Level.*
 - *Parameter 32-2 High Pressure Start Delay.*
 - *Parameter 32-3 High Pressure Response Delay.*
 - *Parameter 36-4 High Pressure.*

11.2.19 Input A Trip/Input B Trip

Cause

The programmable input is set to a trip function and has activated.

Troubleshooting

- Resolve the trigger condition.
- Check the following parameters:
 - *Parameter 7-1 Input A Function.*
 - *Parameter 7-2 Input A Trip.*
 - *Parameter 7-3 Input A Trip Delay.*
 - *Parameter 7-4 Input A Initial Delay.*
 - *Parameter 7-5 Input B Function.*
 - *Parameter 7-6 Input B Trip.*
 - *Parameter 7-7 Input B Trip Delay.*
 - *Parameter 7-8 Input B Initial Delay.*

11.2.20 Instantaneous Overcurrent

Cause

This trip is not adjustable. The current on all 3 phases has exceeded 7.2 times the value of *parameter 1-2 Motor Full Load Current*. Causes can include a locked rotor condition or an electrical fault in the motor or cabling.

Troubleshooting

- Check for jammed loads.
- Check for faults in the motor and in the cables.
- There are no parameters related to this trip message.

11.2.21 Internal Fault X (Where X is a number)

Cause

The soft starter has tripped on an internal fault.

Troubleshooting

- Contact Danfoss with the fault code (X).

11.2.22 Internal Fault 88

Cause

The soft starter firmware does not match the hardware.

11.2.23 LCP Disconnected

Cause

Parameter 1-1 Command Source is set to *Remote LCP*, but the soft starter cannot detect a remote LCP.

Troubleshooting

- If a remote LCP is installed, check that the cable is firmly connected to the soft starter.
- If no remote LCP is installed, change the setting of *parameter 1-1 Command Source*.

11.2.24 L1/L2/L3 Phase Loss

Cause

This trip is not adjustable. During pre-start checks, the soft starter has detected a phase loss as indicated. In run state, the soft starter has detected that the current on the affected phase has dropped below 10% of the programmed motor FLC for more than 1 s. This current drop indicates that either the incoming phase or connection to the motor has been lost.

Troubleshooting

- For the soft starter and the motor, check

- The supply connections.
- The input connections.
- The output connections.
- There are no parameters related to this trip message.

A failed SCR can also cause phase loss, particularly an SCR that has failed open circuit. A failed SCR can only be diagnosed accurately by replacing the SCR and checking the soft starter performance.

11.2.25 L1-T1/L2-T2/L3-T3 Shorted

Cause

During pre-start checks, the soft starter has detected a short-circuited SCR or a short circuit within the bypass contactor as indicated.

Troubleshooting

- Consider using PowerThrough to allow operation until the soft starter can be repaired.
- See also *parameter 6-19 Shorted SCR Action*.

11.2.26 Low Control Volts

Cause

The soft starter has detected a drop in the internal control voltage. This protection is not active in ready state.

Troubleshooting

- Check the external control supply (terminals A7, A8, A9) and reset the soft starter.
- If the external control supply is stable:
 - Check if the 24 V supply on the main control PCB is faulty; or
 - Check if the bypass driver PCB is faulty. Contact the local supplier for advice.
- There are no parameters related to this trip message.

11.2.27 Low Flow

Cause

The flow sensor connected to the smart card has activated low-flow protection.

Troubleshooting

- Check the following parameters:
 - *Parameter 30-5 Flow Sensor Type*.
 - *Parameter 30-7 Flow at 4 mA*.
 - *Parameter 30-8 Flow at 20 mA*.
 - *Parameter 31-2 Low Flow Trip Level*.
 - *Parameter 31-3 Flow Start Delay*.
 - *Parameter 31-4 Flow Response Delay*.
 - *Parameter 36-7 Low Flow*.

11.2.28 Low Pressure

Cause

The pressure sensor connected to the smart card has activated low-pressure protection.

Troubleshooting

- Check the following parameters:
 - *Parameter 30-1 Pressure Sensor Type*.
 - *Parameter 30-3 Pressure at 4 mA*.
 - *Parameter 30-4 Pressure at 20 mA*.
 - *Parameter 32-4 Low Pressure Trip Level*.
 - *Parameter 32-5 Low Pressure Start Delay*.
 - *Parameter 32-6 Low Pressure Response Delay*.
 - *Parameter 36-5 Low Pressure*.

11.2.29 Low Water

Cause

The depth sensor connected to the smart card has activated depth protection.

Troubleshooting

- Check the following parameters:
 - *Parameter 30-12 Depth Sensor Type.*
 - *Parameter 30-14 Depth at 4 mA.*
 - *Parameter 30-15 Depth at 20 mA.*
 - *Parameter 34-1 Depth Trip Level.*
 - *Parameter 34-2 Depth Reset Level.*
 - *Parameter 34-3 Depth Start Relay.*
 - *Parameter 36-9 Well Depth.*

11.2.30 Motor Connection T1/T2/T3

Cause

This trip is not adjustable. The motor is not connected correctly to the soft starter.

Troubleshooting

- Check individual motor connections to the soft starter for power circuit continuity.
- Check connections at the motor terminal box.
- If the soft starter is connected to a grounded delta mains supply, adjust *parameter 20-6 Motor Connection* to match the motor connection configuration.

11.2.31 Motor Overload

Cause

The motor has reached its maximum thermal capacity. The following can cause overload:

- The soft starter protection settings do not match the motor thermal capacity.
- Excessive starts per hour or start duration.
- Excessive current.
- Damage to the motor windings.

Troubleshooting

- Resolve the cause of the overload and allow the motor to cool.
- Check the following parameters:
 - *Parameter 1-2 Motor Full Load Current.*
 - *Parameter 1-4 Locked Rotor Time.*
 - *Parameter 1-5 Locked Rotor Current.*
 - *Parameter 1-6 Motor Service Factor.*
 - *Parameter 5-15 Excess Start Time.*
 - *Parameter 6-10 Excess Start Time.*

NOTICE

Parameters 1-4 to 1-6 determine the trip current for motor overload protection. The default settings of *parameters 1-4 to 1-6* provide motor thermal protection Class 10, trip current 105% of FLA, or equivalent.

11.2.32 Motor Thermistor

Cause

The motor thermistor input has been enabled and:

- The resistance at the thermistor input has exceeded 3.6 kΩ for more than 1 s.
- The motor winding has overheated. Identify the cause of the overheating and allow the motor to cool before restarting.
- The motor thermistor input has been opened.

NOTICE

If thermistors have previously been connected to the soft starter but are no longer required, use the thermistor reset function to disable the thermistor.

Troubleshooting

- Check the following parameter:
 - *Parameter 6-17 Motor Overtemperature.*
- Use the thermistor reset function to disable the thermistor circuit.
- Check for a short circuit across terminals TER-05, TER-06.

11.2.33 Network Communication

Cause

The network master has sent a trip command to the soft starter, or there could be a network communication problem.

Troubleshooting

- Check the network for causes of communication inactivity.
- Check the following parameter:
 - *Parameter 6-13 Network Communications.*

11.2.34 Not Ready

Cause

- The reset input may be active. If the reset input is active, the soft starter does not operate.
- The soft starter may be waiting for the restart delay to elapse. The length of the restart delay is controlled by *parameter 5-16 Restart Delay*.
- Check the following parameter:
 - *Parameter 5-16 Restart Delay.*

11.2.35 Overcurrent

Cause

The overcurrent has exceeded the level set in *parameter 5-5 Overcurrent* for longer than the time set in *parameter 5-6 Overcurrent Delay*. Causes can include a momentary overload condition.

Troubleshooting

- Check the following parameters:
 - *Parameter 5-5 Overcurrent.*
 - *Parameter 5-6 Overcurrent Delay.*
 - *Parameter 6-5 Overcurrent.*

11.2.36 Overpower

Cause

The motor has experienced a sharp rise in power. Causes can include a momentary overload condition, which has exceeded the adjustable delay time.

Troubleshooting

- Check the following parameters:

- *Parameter 5-13 Overpower.*
- *Parameter 5-14 Overpower Delay.*
- *Parameter 6-9 Overpower.*

11.2.37 Overvoltage

Cause

There has been a voltage surge on the mains. Causes can include problems with a transformer tap regulator or off-loading of a large transformer load.

Troubleshooting

- Check the following parameters:
 - *Parameter 5-9 Overvoltage.*
 - *Parameter 5-10 Overvoltage Delay.*
 - *Parameter 6-7 Overvoltage.*

11.2.38 Parameter Out of Range

Cause

This trip is not adjustable.

- A parameter value is outside the valid range. The LCP indicates the first invalid parameter.
- An error occurred loading data from the EEPROM to RAM when the LCP powered up.
- The parameter set or values in the LCP do not match the parameters in the soft starter.
- *Load User Set* has been selected but no saved file is available.

Troubleshooting

- Reset the fault. The soft starter loads the default settings.
- If the problem persists, contact the local distributor.
- There are no parameters related to this trip message.

11.2.39 Phase Sequence

Cause

The phase sequence on the soft starter mains terminals (L1, L2, L3) is not valid.

Troubleshooting

- Check the phase sequence on L1, L2, and L3, and ensure that the setting in *parameter 5-18 Phase Sequence* is suitable for the installation.
- Check the following parameters:
 - *Parameter 5-18 Phase Sequence.*
 - *Parameter 6-16 Phase Sequence.*

11.2.40 Power Loss

Cause

This trip is not adjustable. The soft starter is not receiving mains supply on 1 or more phases.

Troubleshooting

- Check that the main contactor closes when a start command is given and remains closed until the end of a soft stop.
- Check the fuses. If testing the soft starter with a small motor, it must draw at least 10% of the programmed FLC setting on each phase.
- If shunt relay mode is enabled (*parameter 20-8 Shunt Trip Mode*), certain trips may cause the shunt relay to open the circuit breaker.
- There are no parameters related to this trip message.

11.2.41 Pressure Sensor

Cause

The smart card has detected a fault with the pressure sensor.

Troubleshooting

- Check the following parameters:
 - *Parameter 30-1 Pressure Sensor Type.*
 - *Parameter 36-1 Pressure Sensor.*

11.2.42 Rating Capacity

Cause

The soft starter is operating beyond its safe capacity.

Troubleshooting

- Allow the soft starter to cool.
- There are no parameters related to this trip message.

11.2.43 RTD Circuit

Cause

The smart card has detected a fault with the RTD sensor, or the RTD has activated temperature protection.

Troubleshooting

- Check the following parameters:
 - *Parameter 35-2 Temperature Trip Level.*
 - *Parameter 36-10 RTD/PT100 B.*

11.2.44 SCR Itsm

Cause

The SCR current surge rating has been exceeded.

There are no parameters related to this trip message.

11.2.45 SCR Overtemperature

Cause

The temperature of the SCRs, calculated by the thermal model, is too high to allow further operation.

Troubleshooting

- Wait for the soft starter to cool.
- There are no parameters related to this trip message.

11.2.46 Starter Communication

Cause

There is a problem with the connection between the soft starter and the optional communications module.

Troubleshooting

- Remove and reinstall the card. If the problem persists, contact the local distributor.
- There are no parameters related to this trip message.

11.2.47 Starts per Hour

Cause

The soft starter has already attempted the maximum number of starts in the last 60 minutes.

Troubleshooting

- Wait before attempting another start.
- To determine when the waiting period ends, review the log.
- See also *Parameter 5-17 Starts per Hour.*

11.2.48 Thermistor Cct (Thermistor Circuit)

Cause

The thermistor input has been enabled and:

- The resistance at the input has dropped below 20 Ω (the cold resistance of most thermistors is above this value) or
- A short circuit has occurred.

Troubleshooting

- Check and resolve this condition.
- There are no parameters related to this trip message.

11.2.49 Time - Overcurrent

Cause

The soft starter is internally bypassed and has drawn high current during running. (The 10 A protection curve trip has been reached, or the motor current has risen to 600% of the motor FLC setting.)

There are no parameters related to this trip message.

11.2.50 Undercurrent

Cause

The motor has experienced a sharp drop in current, caused by loss of load. Causes can include broken components (shafts, belts, or couplings) or a pump running dry.

Troubleshooting

- Check the following parameters:
 - *Parameter 5-3 Undercurrent.*
 - *Parameter 5-4 Undercurrent Delay.*
 - *Parameter 6-4 Undercurrent.*

11.2.51 Underpower

Cause

The motor has experienced a sharp drop in power, caused by loss of load. Causes can include broken components (shafts, belts, or couplings), or a pump running dry.

Troubleshooting

- Check the following parameters:
 - *Parameter 5-11 Underpower.*
 - *Parameter 5-12 Underpower delay.*
 - *Parameter 6-8 Underpower.*

11.2.52 Undervoltage

Cause

Mains voltage has dropped below the level selected. Causes can include an undersized supply or adding a large load to the system.

Troubleshooting

Check the following parameters:

- *Parameter 5-7 Undervoltage.*
- *Parameter 5-8 Undervoltage Delay.*
- *Parameter 6-6 Undervoltage.*

11.2.53 Unsupported Option

Cause

The selected function is not available (for example jog is not supported in inside delta configuration).

There are no parameters related to this trip message.

11.2.54 VZC Fail Px (Where X is 1, 2, or 3)

Cause

Internal fault (PCB fault).

Troubleshooting

- Contact the local Danfoss supplier for advice.
- There are no parameters related to this trip message.

11.2.55 Zero Speed Detect

Cause

The zero-speed detect input has not closed within the expected duration of a soft stop.

Troubleshooting

- Check that the zero-speed sensor is operating correctly.
- Check that *parameter 2-17 Brake Current Limit* and *parameter 5-15 Excess Start Time* are appropriate for the application.
- Check the following parameters:
 - *Parameter 2-17 Brake Current Limit.*
 - *Parameter 3-19 Brake Current Limit-2.*
 - *Parameter 5-15 Excess Start Time.*

11.3 General Faults

See [Table 215](#) for situations where the soft starter does not operate as expected but neither trips nor issues a warning.

Table 215: General Faults

Symptom	Probable cause/suggested solution
"Not ready" on display	The reset input may be active. If the reset input is active, the soft starter does not operate.
<i>Simul</i> on display	The soft starter is running simulation software. This software is intended for demonstration purposes only and is not suitable for controlling a motor. Contact the local supplier for advice.
The soft starter does not respond to the [Hand on] and [Reset] keys.	The soft starter only accepts commands from the LCP if <i>parameter 1-1 Command Source</i> is set to <i>Remote LCP</i> . Check that the Local LED on the soft starter is on.
The soft starter does not respond to commands from the control inputs.	<ul style="list-style-type: none"> • The soft starter only accepts commands from the inputs if <i>parameter 1-1 Command Source</i> is set to <i>Digital Input</i>. Check the setting of <i>parameter 1-1 Command Source</i>. • The control wiring may be incorrect. Check that the remote start, stop, and reset inputs are configured correctly (see 5.4.3 Start/Stop) for details. • The signal to the remote inputs may be incorrect. Test the signaling by activating each input signal in turn.
The soft starter does not respond to a start command from either the LCP or the digital inputs.	<ul style="list-style-type: none"> • The soft starter may be waiting for the restart delay to elapse. <i>Parameter 5-16 Restart Delay</i> controls the length of the restart delay. • The motor may be too hot to allow a start. The soft starter only allows a start when it calculates that the motor has sufficient thermal capacity to complete the start successfully. Wait for the motor to cool, before attempting another start. • The reset input may be active. If the reset input is active, the soft starter does not operate. • The soft starter may be waiting for control signals via the communications network (<i>parameter 1-1 Command Source</i> set to <i>Network</i>). • The soft starter may be waiting for a scheduled auto-start (<i>parameter 1-1 Command Source</i> set to <i>Clock</i>).
Erratic and noisy motor operation	If the soft starter is connected to the motor using inside delta configuration, the soft starter may not be detecting the connection correctly. Contact the local supplier for advice.

Symptom	Probable cause/suggested solution
Remote LCP shows <i>Awaiting data</i>	The LCP is not receiving data from the control PCB. Check the cable connection.
The soft starter does not control the motor correctly during start.	<ul style="list-style-type: none"> Start performance may be unstable when using a low motor FLC setting (<i>parameter 1-2 Motor Full Load Current</i>). Install power factor correction (PFC) capacitors on the supply side of the soft starter. Disconnect the capacitors during starting and stopping. To control a dedicated PFC capacitor contactor, connect the contactor to a programmable relay set to Run. High levels of harmonics on the mains supply side can affect the soft starter performance. If drives are installed nearby, check that they are properly grounded and filtered.
Motor does not reach full speed.	<ul style="list-style-type: none"> If the start current is too low, the motor does not produce enough torque to accelerate to full speed. The soft starter may trip on excess start time. <div style="text-align: center; background-color: #cccccc; padding: 5px; font-weight: bold; font-size: 1.2em; margin: 10px 0;">N O T I C E</div> <p style="text-align: center;">Make sure that the motor starting parameters are appropriate for the application and that the intended motor starting profile is used. If a programmable input is set to <i>Motor Set Select</i>, check that the corresponding input is in the expected state.</p> <ul style="list-style-type: none"> Check if the load is jammed. Check the load for severe overloading or a locked rotor situation.
Soft stop ends too quickly.	<ul style="list-style-type: none"> The soft stop settings may not be appropriate for the motor and load. Review the settings. If the motor is lightly loaded, soft stop has limited effect.
After selecting adaptive control, the motor used an ordinary start and/or the second start was different to the first.	<ul style="list-style-type: none"> The first adaptive control start is constant current so that the soft starter can learn from the motor characteristics. Subsequent starts use adaptive control.
PowerThrough does not operate when selected	<ul style="list-style-type: none"> The soft starter trips on <i>Lx-Tx Shorted</i> on the first start attempt after control power is applied. PowerThrough does not operate if control power is cycled between starts.
Parameter settings cannot be stored.	<ul style="list-style-type: none"> Make sure to save the new value by pressing [Menu/Store] after adjusting a parameter setting. If pressing [Back], the change is not saved. The soft starter does not show a confirmation. Check that <i>parameter 10-7 Adjustment Lock</i> is set to <i>Read & Write</i>. If the parameter is set to <i>Read Only</i>, settings can be viewed but not changed.
USB full	<ul style="list-style-type: none"> The USB drive may not have enough free space available for the selected function. The file system on the USB drive may not be compatible with the soft starter. The VLT® Soft StarterMCD 600 supports FAT32 file systems. The USB functions of the MCD 600 are not compatible with NTFS file systems.
USB missing	A USB function has been selected in the menu, but the product cannot detect a USB drive. Check that the USB drive has been inserted in the port.
File missing	<ul style="list-style-type: none"> A USB function has been selected in the menu, but the required file cannot be found. Save/load master parameters uses a file called <i>Master_Parameters.par</i> at the top level of the USB drive. For these functions to work correctly, do not move or rename this file.

Symptom	Probable cause/suggested solution
File not valid	A USB function has been selected in the menu, but the file is not valid.
File empty	A USB function has been selected in the menu and the file has been found, but it does not contain the expected content.
Rating not valid	The value of <i>parameter 20-4 Model Rating</i> is incorrect. <i>Parameter 20-4 Model Rating</i> is not user-adjustable. Contact the local supplier for advice.

12 Appendix

12.1 Symbols and Abbreviations

°C	Degrees Celsius
°F	Degree Fahrenheit
AC	Alternating current
CT	Current transformer
DC	Direct current
DOL	Direct on-line
EMC	Electromagnetic compatibility
FLA	Full load amperage
FLC	Full load current
FLT	Full load torque
IP	Ingress protection
LCP	Local control panel
PCB	Printed circuit board
PELV	Protective extra low voltage
PFC	Power factor correction
SCCR	Short-circuit current rating
TVR	Timed voltage ramp

Index

A

Adaptive control.....	119, 130
Adaptive control start.....	65
Adaptive control stop.....	67
Additional resources.....	8
Adjustable delay time.....	125
Auto-start.....	51
Auto-stop.....	51

B

Bypass contactor.....	123
Bypass overload.....	118

C

Certification.....	30
Clearances.....	21
Coast to stop.....	66
Communication options.....	13
Constant current.....	63
Control input.....	129
Current at stop.....	118
Current imbalance.....	118
Current ramp.....	63
Current ratings, in-line installation.....	14
Current ratings, inside delta installation.....	16

D

Date and time.....	48
DC brake.....	68
DOL.....	132

E

Emergency mode.....	61
Ethernet.....	51
Excess start time.....	119, 130
External control supply.....	123

F

Fault finding.....	129
Features.....	12
Fieldbus protocols.....	21
File formats.....	50
File locations.....	50
FLC.....	22, 72, 120, 122, 126, 130, 132
FLT.....	71, 132
Full load current.....	13
See FLC	
Fuses.....	24, 25, 26, 27

G

Gain setting.....	66
General faults.....	129

H

Heat sink.....	121, 121
Heat sink overtemperature.....	121
Heatsink overtemperature.....	121

I

IEC fuses.....	24
In-line connection.....	120
Input A trip.....	121
Input B trip.....	121
Inside delta.....	72
Inside delta configuration.....	120
Internal fault.....	122

J

Jog.....	71
----------	----

K

Kickstart.....	64
----------------	----

L

LCP.....	132
LCP, local.....	56
LCP, remote.....	57
LED descriptions.....	58
Load settings.....	49
Low battery.....	118
Low flow.....	123
Low pressure.....	123

M

Main contactor.....	126
Mains supply.....	120, 126
Maximum fuse rating.....	25, 26, 27
Motor branch circuit.....	23
Motor overload.....	124
Motor thermistor.....	32, 125, 125
Motor windings.....	118, 124

N

Network address.....	51
Network communication.....	125

O

Overcurrent.....	122, 128
Overtemperature.....	121, 121

P

Peak currents.....	23
Performance graph.....	59
Power correction capacitor.....	130
Power loss.....	126
PowerThrough.....	60, 100, 123, 130
Programmable input.....	121
Protection settings.....	124
Protocols.....	21

Q

Quick set-up.....	46
-------------------	----

R

Real-time clock.....	118
----------------------	-----

Remote LCP.....	122	Supply connection.....	123
Reset.....	118	Symbols.....	9
Reset command.....	60		
Reset input.....	33	T	
Reset thermistors.....	53	Terminal A7.....	123
Reverse operation.....	70	Terminal A8.....	123
		Terminal A9.....	123
S		Thermal capacity.....	124, 129
Save settings.....	49	Thermal model.....	54
SCR.....	123	Thermistor.....	128
SCR, failed.....	119	Timed voltage ramp.....	66
Secondary motor settings.....	72	See TVR	
Short circuit.....	123	Trip behavior.....	61
Simulation.....	48	TVR.....	66, 67, 132
Simulation software.....	129		
Soft braking.....	69	U	
Start command.....	60	Undercurrent.....	128
Starting profile.....	130	USB.....	33, 50, 50, 130
Stop command.....	60		

ENGINEERING
TOMORROW



Danfoss A/S
Nordborgvej 81
DK-6430 Nordborg
www.danfoss.com

Danfoss can accept no responsibility for possible errors in catalogues, brochures and other printed material. Danfoss reserves the right to alter its products without notice. This also applies to products already on order provided that such alterations can be made without subsequential changes being necessary in specifications already agreed. All trademarks in this material are property of the respective companies. Danfoss and the Danfoss logotype are trademarks of Danfoss A/S. All rights reserved.



* 1 7 5 R 1 1 7 4 *



* M 0 0 2 6 1 0 1 *